

ceramic arts *yearbook* and annual buyers guide



Raven Halfmoon,
Ceramic Artist of
the Year



Plug-n-Fire Kiln



**GREAT STARTER KILN OR TEST KILN
FOR PRODUCTION POTTERS.**



**WORKS ON STANDARD
HOUSEHOLD OUTLET
15 amp - 120 volt**

NEW ACCESSORIES



TALL STAND OPTION NOW AVAILABLE



ROLLING STAND UPGRADE



VISIT FOR DETAILS

**HOTKILNS.COM
/KILNS/PLUG-N-FIRE**

BOTZ PRO
GLAZES
BLICK
EXCLUSIVE



GLAZE GOALS

Make it happen with unbeatable prices on the brands you love.



Nidec *Speedball*  **SKUTT** *Mayco* **BOTZ**

Shop in stores and online.





BLICK®

DickBlick.com 800.828.4548

© Copyright 1999 - 2024 Blick Art Materials, LLC. All Rights Reserved.

Beyond Compare.

No other kiln can match the features & benefits of a Tucker's Cone Art Kiln.

- 
PATENTED "LID-LIFTER"
For lids that lift with ease.
- 
DOUBLE WALL DESIGN
Extra insulated walls for significant energy savings, and longer parts life.
- 
MULTI-ZONE CONTROL
Multiple thermocouples means even firings from top to bottom.
- 
FLOOR ELEMENTS
Heated floors help keep temperatures even all around.



But don't just take our word for it...



Robert Siegel of the successful LA-based studio, Robert Siegel Handmade, *relies on three Tucker's Cone Art Kilns to keep up with his busy production schedule* of dinnerware collections, limited edition and custom porcelain pieces.

Robert Siegel
robertsiegelstudio.com

Cybèle B. Pilon uses the words "easy to use" "reliable" and "consistent" to describe her Cone Art making it stand out from all the other kilns she's used before and giving her peace of mind.



Cybèle B. Pilon
cybelebpilon.com



Peter Pincus pushes boundaries with the sophisticated methods he employs to create his exceptional body of colorful porcelain. "The kiln I trust? A Tucker's Cone Art Kiln."

Peter Pincus
peterpincus.com



The Original True Cone 10 Kiln.
Tucker's Cone Art Kilns
 15 West Pearce St, Unit #7
 Richmond Hill, Ontario CANADA L4B 1H6
 800.304.6185 | info@coneartkilns.com
 Cone Art Kilns  @Cone.Art.Kilns

www.coneartkilns.com

ceramic arts yearbook and annual buyers guide

Ceramic Arts Yearbook and Annual Buyers Guide
 A Supplement to Ceramics Monthly and Pottery Making Illustrated

Publisher and Managing Director
 Bill Janeri

Managing Editor
 Holly Goring, *Pottery Making Illustrated*

Editor
 Katie Reaver, *Ceramics Monthly*

Assistant Editor
 Margaret Kinkeade

Assistant Copy Editor
 Kaitlyne Flanigan

Production Manager
 Kerry Burgdorfer

Advertising
National Sales Director Mona Thiel
 mthiel@ceramics.org
 Telephone: 614-794-5834
Advertising Services Pam Wilson
 pwilson@ceramics.org
 Telephone: 614-794-5826

Editorial and Advertising offices
 550 Polaris Pkwy, Suite 510
 Westerville, Ohio 43082 USA
editorial@ceramicsmonthly.org

The American Ceramic Society
Executive Director Mark J. Mecklenborg

Ceramic Arts Yearbook and Annual Buyers Guide is a supplement to *Pottery Making Illustrated* (ISSN 1096-830X) and *Ceramics Monthly* (ISSN 0009-0328) and is published by The American Ceramic Society, 550 Polaris Pkwy., Suite 510, Westerville, Ohio 43082, USA.

Photocopies: Permission to photocopy for personal or internal use beyond the limits of Sections 107 and 108 of the U.S. Copyright Law is granted by The American Ceramic Society, provided that the appropriate fee is paid directly to Copyright Clearance Center, Inc., 222 Rosewood Dr., Danvers, MA 01923 USA; (978) 750-8400; www.copyright.com. Prior to photocopying items for educational classroom use, please contact Copyright Clearance Center, Inc.

This consent does not extend to copying items for general distribution, for advertising or promotional purposes, or to republishing items in whole or in part in any way and in any format. Please direct republication or special copying permission requests to the Ceramic Arts Publisher, The American Ceramic Society, 550 Polaris Pkwy., Suite 510, Westerville, OH 43082, USA.

Copyright © 2024 The American Ceramic Society
 All rights reserved

CERAMIC ARTS NETWORK

ceramics
 MONTHLY

Pottery Making
 Illustrated

iCAN International
 CERAMIC
 ARTISTS
 NETWORK

CLAYflicks
 STREAMING VIDEOS

ceramic RECIPES
 Get excited. Get involved. Get results.

Nidec

“I love the portability, design, and affordability of the SHIMPO ASPIRE. Being able to take it with me while moving across the country has allowed me to not only maintain my skills, but take my pottery to the next level.”

Follow Aaron @aaronbuckleyceramics



DAIDO (USA) CO., LTD.

175 Wall Street, Glendale Heights, IL 60139 USA • Phone: (800) 237-7079 • (630) 924-7138 • info@shimporceramics.com • www.shimporceramics.com

contents



6 Ceramic Artist of the Year: Raven Halfmoon

Chosen by the editorial staff of *Ceramics Monthly* and *Pottery Making Illustrated*, this year's Ceramic Artist of the Year, Raven Halfmoon, was selected for her excellence in creating a prolific body of work, propelling the field of ceramic arts forward and outward, and uplifting her community.

12 Facilities

Leach Pottery is undergoing a site-wide transformation: *The Leach Pottery: the next 100 years*. The expansion will enhance the visitors' experience and create more opportunities to engage in the unique story of the internationally renowned site.

15 New Products

Every year, new products, improvements on existing products, and updated technology provide the clay world with new things to try and new ways of making our studio work easier.

20 Events

- 20 American Pottery Festival
- 21 58th Annual NCECA Conference: Coalescence
- 21 Minnesota Pottery Festival
- 22 1001 Pots
- 22 37th Annual California Conference for the Advancement of Ceramic Arts
- 23 Clay Fest
- 23 Sydney Craft Week
- 24 Midwest Pottery Fest
- 25 Firefest
- 26 Salad Days
- 27 Silver City CLAY Festival 2024

28 Pottery Tours and Regional Craft Shows

Find a pottery tour near you, or visit one online.



cover: (Clockwise starting with top left) The First Students Cube Gallery at Leach Pottery, 2023; Ceramic Artist of the Year Raven Halfmoon in the studio. *Image courtesy of the artist and Salon 94. Copyright Raven Halfmoon. Photo: Elisabeth Bernstein.*; Clay Fest, Philadelphia, Pennsylvania, 2024; FireFest, Star, North Carolina, 2024.

32 Short-Term Resident Artists

A lot of great ceramic work is made by resident artists. Check out who they are and where they're working.

42 Awards

- 42 Center for Craft Grants and Fellowships
- 43 James Renwick Alliance for Craft's Master of the Medium Award
- 43 Jerome Ackerman Endowed Internship
- 44 Pottery Museum of Red Wing Award
- 44 Warren MacKenzie Advancement Award (WMAA)
- 44 Early Career Artist Residencies
- 45 McKnight Artist Fellowship for Ceramic Artists
- 45 McKnight Residency for Ceramic Artists
- 46 Van Achterbergh Prize 2024
- 46 NEA Grants

48 Icons Remembered

Each year, the clay community loses people who have had a great impact on the lives and professions of many.

52 New Media

Need a good read that will motivate you in the studio? Or, looking to listen for inspiration via a new podcast? Check here for the latest.

57 Buyers Guide: Geographic Locator

No matter what you're looking to purchase for the studio, this handy guide will tell you who sells what, and where they are.

62 Buyers Guide: Company Directory Listings

Full contact information and descriptions of the manufacturers and suppliers serving ceramic studios.

71 Index to Advertisers





Raven Halfmoon

— Ceramic Artist of the Year —

Editors: You focus on communicating messages about indigeneity and Caddo culture within your personal artwork and studio practice. What led you to this work?

Raven Halfmoon: The influence of my family, both on my mother's side and my father's side, strongly influenced me to incorporate messages about culture and identity in my work. Although I began drawing and painting as early as I can remember, as I evolved in age and experience, I reflected more and more upon not only our Tribal culture but also on the history of Native people in general. My maternal "Grammie" was Rebecca Halfmoon, and she was on the Caddo Tribal Council. Her father, Hubert Halfmoon, was the Tribal Chairman in the late 80s. My maternal great-grandmother was highly respected because of her work with the Indian Clinic in Oklahoma City, which was even named after her. My mother worked for the Caddo Nation for almost ten years, beginning when I was about five. I attended cultural summer camps and Caddo dances and saw my mother's

passion for her work in cultural preservation. Our family often traveled with my mother on trips to the Caddo homeland as part of her job—visiting places like Caddo Lake in East Texas and many museums with Caddo collections.

My father also comes from a large extended Native family. His parents, who are Otoe and Cherokee, have always been passionate about Native art and supporting Native artists. They have a phenomenal collection that is ever present in their home, and art is always the topic of discussion there. I grew up seeing the artwork of Archie Black Owl, Bennie Buffalo, Enoch Kelly Haney, and so many others at their home and at my uncle's Native art gallery. My father has worked for the Cherokee Nation for well over ten years, supporting the efforts of the Tribal Government. We are a Native family; we always have been. Reflecting upon and incorporating my heritage into my work is natural because that is who I am. I am an enrolled citizen of the Caddo Nation, and I spent a lot of time there learning.

Eds: Why do you use clay? What role does scale play in your work?

RH: For thousands of years, the Caddo people were known for their beautifully crafted and decorated pottery. However, due to contact and forced removal from our beloved homelands, we had lost much of the tradition and access to the clay sources we had used for millennia. Still, I was focused on painting and school, and it wasn't until taking a ceramics class in college that my love for clay truly woke up. My mom joked that of course, I would love working with clay; it was in my DNA! I also saw the different patterns and symbols etched into the pottery when I visited the Arkansas Archaeological Survey while studying at the University of Arkansas. One of the reasons I selected that school is its program for students who are enrolled citizens of the Tribal Nations indigenous to Arkansas.

I greatly respect the Caddo pottery tradition, but I also knew early on that I wanted to create something new and make my mark with clay. During my anthropological studies, I became inspired by the Moai (Easter Island heads) and other large works. After graduating from college, I began to make fairly large-scale clay sculptures. Scale is very important in my work, and as my practice has evolved, so has my drive to see how large I can build. Building large is my way of creating a humbling and awe-inducing experience for the viewer. In my own experiences in nature, among the mountains of Montana and places like Yellowstone National Park, I was struck by how the scale humbled and inspired me. It created an awe-inducing silence. That is my inspiration for large-scale works—the idea of Native people unapologetically commanding and taking up space.

Eds: What infrastructure do you have in place to construct, fire, finish, package, ship, and install your monumental sculptures? Is this a collaborative effort with the galleries that represent you? Do you work with studio assistants?

RH: Because of the scale of some of my recent works, I absolutely require support! Even finding a kiln large enough to accommodate my sculptures has been a challenge. Constructing is frequently done by myself but as my practice has grown, I have been lucky enough to work with a few studio assistants and artists who were able to help me build some of the largest pieces. I have often hired students from ceramics departments where I am on-site building and they have been a great asset.

Crating and shipping are always vital steps in the process after the work is complete. Crates must be custom-built for each piece. My galleries and the museums where my pieces are shown frequently financially support that effort. While I used to build my own crates, I greatly appreciate when the experts can handle that part. Installation often requires heavy equipment and, although high-fired clay is very sturdy, one must be very careful with ceramics, using padding and great skill to set works into place.

Eds: Can you describe the ways that social activism and narrative expression have become a larger part of the ceramics field? How has this affected your career path? How has it impacted your studio work?

RH: I think it is very exciting that the ceramics field reflects the social activism of our time. In a way, that is exactly what art can do and has done through the millennia—art, ceramics, or otherwise, can be made to speak about the perspective or experience of the



1 Raven Halfmoon working with clay in her studio, 2024. *Photo: Leslie Halfmoon.* **2** Raven Halfmoon with her dog, Teddy B, in front of her sculpture, *Flagbearer*, 13 ft. (4 m) in height, stoneware, glaze, armature, 2022.

maker, to call attention to social injustices, and to share differing perspectives on history. This expression is perfect for my work because it gives voice to my ancestors, the Caddo people, and other Native Nations who have faced unfathomable hardships, and yet, we are still here. This narrative has become integral to my sculptures and audiences yearn to understand the meaning behind the pieces.

However, as an artist, I want each individual to approach my work, experience it, and interpret it for themselves. Art is beautiful in that sense. We each bring our own histories and perspectives with us, and through those individualized eyes, the art takes on a unique meaning. I certainly am inspired by particular people or things when creating, but my hope is that my art speaks for itself and can stand on its own without me overdirecting the viewer.



3

Eds: Given how meaningful and emotional it can be to connect your sculptures with the ancient tradition and spirit of your ancestors, how do you recharge and protect your mental wellbeing while staying committed to your work?

RH: I have experienced, as many artists do, the intensity of working long hours at multiple jobs, hustling to find opportunities, and having to be my own accountant, business, and marketing manager, all while trying to stay creative and productive in the studio. I also feel responsible for conveying the history of my Tribe and sometimes the broader Native experience because of what I know about history. While working with the physicality of clay itself is very healing to me, as artists, we always experience mental and physical burnout. I have learned that to invest in the process fully and the spirit of my practice, I need to feel healthy, rested, inspired, and grounded.

Physically, I have to heal my body after intense periods in the studio—building large-scale sculptures by hand, coil by coil, certainly takes a toll on the body. I have learned to tune in to my body's needs. I have a massage therapist who helps my body recover. I stay active by running and doing other physical things, such as caring for my horses. My animals are such a blessing. They help remind me to take breaks, slow down, focus on them, and be present. I do find that I respond to seasonal changes—for example, I have always enjoyed the dark and quiet of winter for a time to build. I have learned to tune in to my needs so that I can bring my best to the creative process. I also have spiritual practices that I have learned from my family and Tribe.



4



5

3 Fry Bread Hips and Bright Red Lips, 4 ft. 3 in. (1.3 m) in height, stoneware, glaze, 2020. 4 Riding in the Four Directions, 4 ft. 3 in. (1.3 m) in length, stoneware, glaze, 2023. 5 E-a'-ti-ti (Sister in Caddo), 4 ft. 8 in. (1.5 m) in height, stoneware, glaze, 2021.

Eds: How do you hope the larger community of viewers outside of the ceramics field will interpret your use of clay and what do you hope they will get from it? How is your clay work received by audiences who are more accustomed to other media in fine art galleries?

RH: I hope that my sculptures can be appreciated outside of the ceramics field for what they convey and how they speak to people. The medium for me has particular meaning because of my Tribe's ancestral use of clay, and I hope audiences find that interesting and educational. The Caddo ceramic tradition has dramatically informed my overall process of working with clay. I love the idea of working with clay the way my ancestors did for thousands of years. Although I do not focus on replicating traditional Caddo vessels, the symbols, shapes, forms, and even their approach to mixing clay for strength—these ceramic traditions continue to live in my work. For example, my piece *Caddo Effigy Sisters* emulates the form of Caddo water bottles. The clay body I use is a unique mix I created that is a dark chocolate color—a nod to the clay my ancestors often used in our homelands coming from rivers such as the Red River and the Kiamichi River. My works have been very well received by a number of museums and fine art galleries and I remain grateful for the number of museums that have acquired my sculptures for their permanent collections. This tells me that my work is reaching broader audiences.

Eds: How are you inviting a collector to be invested in clay?

RH: I hope collectors appreciate the deep connections and rich history of clay and ceramics in my culture and other Native cultures. It is an ancient practice and medium used by generations of people who developed a scientific-level understanding of its structure, abilities, and strength. It is a living thing that requires in-depth knowledge of how it dries, how it reacts to heat and fire, and how it can be tempered to strengthen it. And when all of these techniques are employed well, a ceramic piece can live to be hundreds of years old. In my culture, we revere the earth as a life-giving entity; when working with this element, you are connected to it. If you have seen the ancient ceramics of my ancestors and other Tribal cultures in North and South America, you see the artisans' mastery level. Ceramics are fine art, and I hope collectors appreciate the beauty, history, and technique of working with clay.

Eds: You've stated that the Caddo culture is matrilineal and that your inspiration often draws from the experiences and identities of the women in your family and ancestral line. What does your family make of your work?

RH: My family are some of my biggest supporters. As far back as I can remember, my parents have encouraged me to pursue art. They have helped me apply for grants and residencies, have been my proofreaders, and have weighed in on my work. My parents, grandparents, aunts, and uncles remain sources of support and strength for me. I have been so blessed to have a family that not only respects art but also has a deep appreciation for Native art. Even my broader Tribal family encourages me and supports me as an artist. There was never



6 HASINAI (*Our People in Caddo* (detail), stoneware, glaze, 2021. **7** Halfmoon in the studio with works in progress.



8



10



9



11

8 *Caddo Effigy Sisters*, 36 in. (91.4 cm) in height, clay, glaze, 2023. 9 *Sunsets in the West*, 7 ft. 3 in. (2.2 m) in height, stoneware, glaze, 2023. 10 *ONE'-TEH*, 4 ft. 4 in. (1.3 m) in height, stoneware, glaze, 2020. 11 *NDN Rockstar*, 5 ft. 4 in. (1.7 m) in length, clay, glaze, 2023.



12 Raven Halfmoon's *Flagbearer* (installation view) at The Aldrich Contemporary Art Museum. Photo: Jason Mandella. 13 *Weeping Willow Women*, 6 ft. (1.8 m) in height, ceramic, glaze, 2023.



an expectation placed on me to do anything other than what I chose, and perhaps it is that very freedom that inspired me to pay homage to my ancestral line while, at the same time, putting forth my voice and identity as a contemporary female Native artist.

Eds: You've garnered attention as an Indigenous woman artist, making work centered on identity. How has your artwork and success impacted those communities with which you are connected?

RH: I am so thankful for my Tribal community and for fellow Native artists who have inspired and supported me. I have had positive feedback from some Native individuals who have seen my work in person. One of the most heartwarming was a gentleman who shared that he took his children each weekend to see my sculptures because it was like attending church for them. He said it was a healing and powerful experience, and they wanted to be around the sculptures. That was truly something I will never forget.

I design my figures to be powerful or to convey a certain feeling. They demand your attention, and they do dare to take up space. I hope my Tribal community, my home state of Oklahoma, and the supportive network of artists, museums, curators, and galleries continue to respect my vision as an artist. Art is very personal to both the maker and those who admire it—even if my work is not someone's favorite, I appreciate the art community's support of an

artist being true to their vision. I hope my art helps Native people feel they are seen and helps the public understand that Native people are still here. So often, it feels like we are an invisible sector in society. My art has been a way of saying, "We are still here, and we are still powerful." Any success I have is born from the brilliance, intelligence, strength, and resilience of my ancestors, my culture, and my family. I greatly respect the role of women in my culture and in Native society; they are life-givers, caregivers, and the pillars of strength and love that nourish families and communities.

Eds: Do you feel that your identity as an artist has changed or grown over time?

RH: At a baseline level, my identity as an artist has always been present. I have identified as an artist from a very young age; in a sense, that fundamental identity never changes. What changes are the mediums I work with, my subject matter, my inspiration, and my overall technical expertise. I will always identify as an artist; it is who I am. But as an artist, I want to continue to evolve in terms of knowing myself, challenging myself, and staying curious, creative, and inspired. I remain a female, a Tribal citizen, and an artist, among other titles. All of those identities merge into my work.

To learn more, visit www.ravenhalfmoon.com.

facilities

Leach Pottery Expansion

The Leach Pottery has secured £3.49m (\$4.58m) funding from the National Lottery Heritage Fund to support the development of the Leach Pottery in St Ives, Cornwall. The Leach Pottery is currently undergoing a site-wide transformation project: *The Leach Pottery: the next 100 years*. Their capital program will invest in new learning and production studio facilities, repair and conserve historic buildings, and reinterpret the site through new displays and exhibition spaces. The project will significantly enhance the visitors' experience and create more opportunities to engage in the unique story of the internationally renowned site.

The facility development will include:

- A new Learning and Production Centre to provide more classes and workshops, and increase pottery production.
- A new reception and cafe building.
- Refurbishing and extending the existing museum to include an introductory gallery, hands-on exhibits, and a trail.
- Revamping the existing shop in the listed Pottery Cottage.
- Creating a temporary gallery for shows of contemporary pottery for sale.
- Converting the Cube gallery into an archive study center and library.
- Improving facilities for visiting artists.

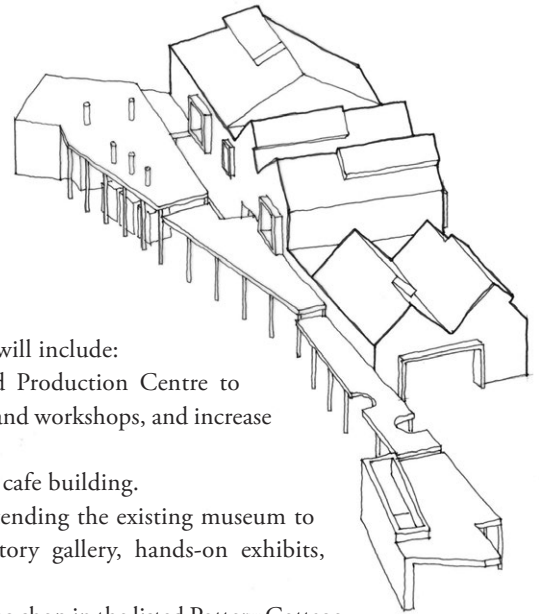

Top Architect's sketch of Leach Pottery. Photo: Dow Jones Architects. 1 Leach Pottery Museum Entrance, Leach Pottery. 2, 3 The First Students Cube Gallery at Leach Pottery, 2023.



Additionally, Leach Pottery is set to expand with the creation of seven new jobs. The six new roles are funded by the National Lottery Heritage Fund as part of the major development of the historic pottery and include:

- Two new coordinator roles within the learning program, *Make with Leach*. Make with Leach offers participants who would otherwise face barriers accessing the Leach Pottery ways of engaging with the pottery and ideas of the Leach Pottery.
- A Communications and Marketing Apprentice to support the delivering Leach Pottery's communications and marketing on a day-to-day basis.
- A Volunteer Coordinator who will help ensure that the Leach Pottery evolves as a nurturing and exciting place for volunteers to be part of the team.

There are also three roles relating to the development of the new on-site museum:

- An Interpretation Lead to support interpretation of the redevelopment of the Leach Pottery site that will cater to diverse audiences.
- An Interpretation Curator to develop new museum displays. This will include creating opportunities for creating content with the local St Ives community and the national studio pottery community.
- A Curatorial Assistant, Collections, to develop and deliver interpretive content and support all aspects of preparing collection displays, exhibitions, and loans across the site.

The Leach Pottery is managed by the Bernard Leach (St Ives) Trust Ltd, a registered charity founded in 2005. The Trust's primary objectives are to further the development of studio pottery, provide training in the art, craft, and making of pottery, and advance the public's education of the life and work of Bernard Leach and his circle.

Learn more about the Leach Pottery expansion here: www.leachpottery.com/leach-pottery-proposed-development.



4 Impression of how Leach Pottery will look after completed renovations. Photo: Dow Jones Architects. 5 Leach Pottery potters. Photo: Jonny Weeks. 6 Learning at the Leach Pottery. Photo: Ellen Love. 7 Sake bottle with cups, Leach Pottery. Photo: Matthew Tyas.

COSMOS

GLAZES THAT ARE OUT OF THIS WORLD

Amaco.com



LEARN MORE
ABOUT CO-13
MARS CRYSTAL

new products

Brennan Pottery

The **Brennan Pottery Clamp** (A) is a decorating tool designed to allow you to work hands free—meaning that it acts like a third hand and holds your pot so you don't have to. What makes this tool unique is that it holds your pot from the inside with three foam-covered parts that expand inside the pot, securing it. The Pottery Clamp utilizes a set of bearings that enable your pot to rotate like a wheel on a roller skate and can be pivoted to adjust to a comfortable working angle. Not only does it make it easier to work on 360° of your pots, but it also reduces the risk of smudging your surfaces since you no longer have to hold vessels by the outside. This is a great ergonomic tool for pottery making as it reduces strain and injuries to hands, wrists, and shoulders caused by hours of holding pots.

www.potteryclamp.com



A

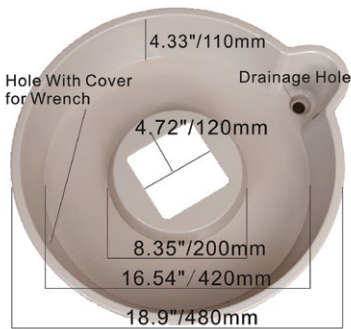

B

Chinese Clay Art

Drainable Splash Pan (B) (international patent pending) has been fitted to accommodate several name-brand pottery wheels. Together with the Easier Cleaning Tool allows for quick clean up during and after throwing, saving your energy for other studio tasks.

www.chineseclayart.com

Clay Stamps

Clay Stamps creates laser-engraved **Custom Rollers** (C). The rollers are 1 inch in radius and can be made from customer-provided designs. This rolling stamp can be used for any kind of clay and a variety of media including PMC, polymer clay, soap, and wax.

www.claystamps.com/shop/custom-rollers



C



D

Hand + Fire Pottery Tools

Artisan pottery tools (D) designed and handcrafted by potter Sage Cortez. All Hand + Fire wooden tools are made from fallen or salvaged Oregon hardwood. This means every piece is entirely individual, bearing its own unique knots, texture, and grain. The hammering on the brass surfaces of tools is not only aesthetically pleasing, but it also hardens the metal to withstand gentle bending with use. Over time, a unique patina will develop.

www.handandfire.com

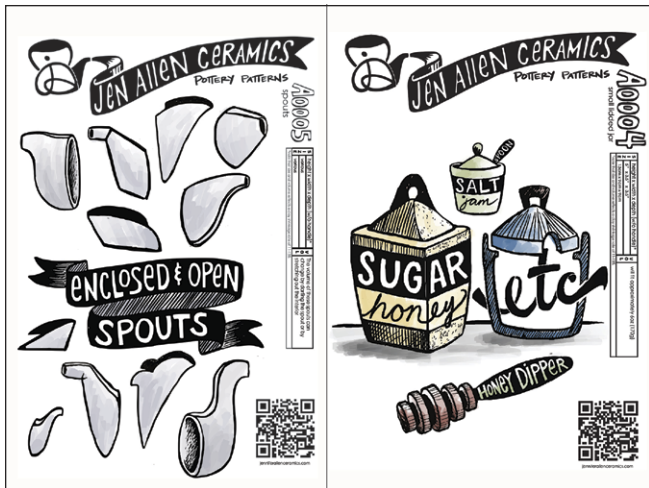

E

Jen Allen Ceramics

Jen Allen Ceramics proudly introduces a new series of templates for slab building, called **Pottery Patterns** (E). Inspired by traditional sewing patterns, these printed templates come inside an illustrated envelope or as downloadable PDFs. All Pottery Patterns include detailed directions to guide you through each step of the process. Perfect for both novices and experts, Pottery Patterns help you create repeatable forms with ease. Jen Allen Ceramics continues to empower and inspire the pottery community, making slab building fun and approachable.

jenniferallenceramics.com

LittleChip Tools

LittleChip Tools designs and produces **extruder dies** (F) in a range of patterns. Single-piece construction means the dies are always centered. Dies are available for 2–6-inch extruders for all major wall-mount and hand-held brands. Large format cutters are also available to make plates, platters, cheese boards, bread pans, and other projects. All products are 3D printed in the US using a polymer made from starch (not petroleum). Inquiries for custom extruder dies, cutters, or stamps are welcome.

littlechiptools.com

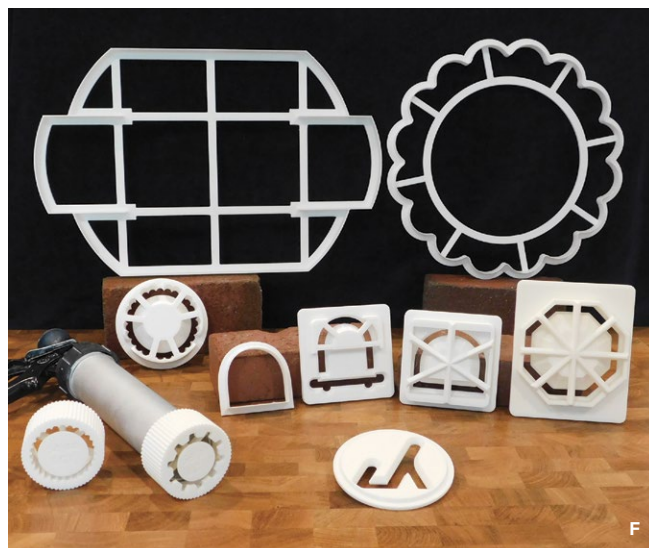

F



G

Mike Cerv

Precision-cut templates are made out of durable and reusable tar paper. These not only provide an outline to cut reproducible forms, but they also provide stability as you build. Adhere the template to your slab, cut the outline, form your shape, and peel the template away to make whole sets of matching pots. **Tar Paper Templates** (G) are excellent for hobby potters, educators, or anyone wanting to build duplicates.

mikecervpots.myshopify.com/collections/templates

MKM Pottery Tools

MKM Pottery Tools has all sorts of new designs, from flying pigs to wildflowers to mushrooms. Enjoy these beautiful **wood stamps** (H) and **rollers** with their fun designs, carving, ability to release, and a finish that allows them to last forever.

www.mkmpotterytools.com



I



H

MudTools

Meet the **DEX Tool** (I), a versatile double-ended stylus available in five styles. Made from high-quality, durable stainless steel, this thoughtfully weighted tool is perfectly balanced for precise control and effortless movement. Ideal for various techniques, use Styles 1–3 for precise sgraffito, mishima, and signing, while Styles 4 and 5 are perfect for drawing, surface embellishments, and form alterations.

mudtools.com

Ritual Glaze

Ritual Glaze is the first-ever glaze company specializing in **textural glazes** (J) and is a 100% female-founded startup based out of Portland, Oregon. Ritual Glaze offers 15 gloopy, puffy, and crawling glazes in a range of colors and firing temperatures. Their online FAQ and tutorial videos will help you get started. Glazes pictured, clockwise from top left: Supergloop Pastel Green, Melt Gloop Hot Pink, Suckerpunch Blue, Melt Gloop Pastels layered over Satin Matte Pastel Orange, Grumdrops Pastels, Bead White.

ritualglaze.com



J

Shalya Marsh Studios

New **tar-paper stencils** (K) make it easy to create repeatable, dynamic surface patterns. These stencils cater to a wide range of users, from the novice potter to the seasoned studio artist, providing crisp, clean lines and bold, graphic patterns that enhance any ceramic piece. Their newest stencils for cups and mugs are available in multiple designs and sizes. Mug Flats create intricate textures and act as a template to support the clay when making a cup or mug. If you have your own craft cutter, their stencil designs are also available as digital downloads.

www.shalyamarshstudios.com



K



L

Wizard Glaze

Step into the future with Wizard Glaze, an innovative brand specializing in **special effects and textural glazes** (L). Their goal is to provide a diverse range of contemporary glazes that empower artists to bring their creative visions to life. Gloop, the bestseller, features an easy-to-master formula and is offered in a wide spectrum of vibrant hues. Meltdown creates long viscous drips.

wizardglaze.com

Xiem Tools

Xiem has several new tools out this year, including **The Dot** (M), a clay level and trimming wheel in one. The clay level is designed to help level clay work on a bisque chuck or any trimming support before trimming or any work that needs to be level. The trimming wheel is designed to hold down the greenware pottery on the wheel for ease of trimming needs. The **Rim Rib** (N), is designed to create precision rim thicknesses for handbuilding and wheel-throwing pottery. The **Foam Brush** (O), is made from the highest-quality foam and secured on a plastic handle for wax-resist, oxides, stains, inks, and glaze application. Perfect for hard-to-reach areas. **Potter's Clay Gauge** (P), is a caliper and depth measurement tool in one. It is ideal for measuring inner, outer, and depth measurements for both thrown and handbuilt clay works. Also check out their Clay Finishing Tools, Edger Ribs, Marking Dot, and the X-Board Deluxe.

www.xiemtoolsusa.com



M



N



O



P

LagunaClay.com

@LagunaClay

@LagunaClayCo



Laguna CLAY COMPANY

Your one-stop shop
for everything ceramics

Scan here
for more



events

American Pottery Festival

- September 8–10, 2023
- Minneapolis, Minnesota
- www.northernclaycenter.org
- The 25th annual American Pottery Festival, Northern Clay Center's (NCC) annual fundraiser, featured the work of 25 US ceramic artists offering a wide array of materials, aesthetics, and approaches to clay. In addition to the exhibition, the weekend was filled with artist presentations, workshops, panel discussions, and casual gallery conversations.

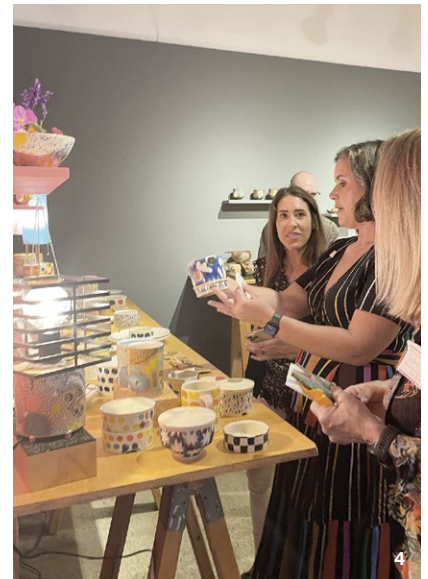

1 A display of work by S.C. Rolf at American Pottery Festival 2023. 2 American Pottery Festival 2023 artist, Kristina Batiste (right) discussing her work with attendees. 3 A display of work by Taylor Sijan at the American Pottery Festival 2023. 4 NCC Sales Gallery Manager Rachel Nusbaum, shows customers a selection of work by Didem Mert at American Pottery Festival 2023. 5 Olivia Tani's work on display at the American Pottery Festival 2023. All photos: Northern Clay Center.

58th Annual NCECA Conference: Coalescence

- March 20–23, 2024
- Richmond, Virginia
- www.nceca.net
- The National Council on Education for the Ceramic Arts (NCECA) held their annual conference in Richmond, Virginia, complete with dozens of exhibitions, keynotes, panel discussions, and live demonstrations presented by over 100 artists and educators including demonstrating artists Paul S. Briggs, Andréa Keys Connell, Jabulile Nala, and Justin Paik Reese.



6



7



8

6 Demonstrating artist Jabulile Nala working on a Ukhamba vessel, 2024 NCECA Coalescence conference, Richmond, Virginia. *Photo: Jabulile Nala.* 7 Demonstrating artist Paul S. Briggs during the 2024 NCECA Coalescence conference, Richmond, Virginia. *Photo: NCECA/Germaine Watkins.* 8 2024 NCECA Emerging Artists, left to right: Magdolene Dykstra, Erika NJ Allen, Teddy Osei, Gloria Han, Robert King, and Isaac Scott at the 2024 NCECA Coalescence conference, Richmond, Virginia.

Minnesota Pottery Festival

- July 27–28, 2024
- Masonic West River Park in Hutchinson, Minnesota
- www.mnpotteryfestival.com
- The 12th annual Minnesota Pottery Festival welcomed over 3000 people. There were 39 potters from Minnesota and beyond set up selling their work, and providing demonstrations of techniques, cooking, and raku firing. The Potters Olympics are always a highlight as 12 of the show's potters competed, with the grand prize being a Shimo Whisper Lite kiln donated by Continental Clay and Shimo. Next year's event will be held on July 26–27, 2025.



9

9 Mallory Keating blindfolding Jason Kaping during the Potters Olympics. 10 Gruchalla Rosetti Pottery from Duluth, Minnesota. 9, 10 Photos: Incognito Photography.



10

1001 Pots

- July 5–August 18, 2024
- Val-David, Canada
- www.1001pots.com
- Celebrating its 35th year, 1001 Pots highlights the best of contemporary ceramics in the heart of Quebec. Visitors were able to view and collect the work of over 100 ceramic artists, support local artisans, try their hands at introductory ceramic courses, and meet current residents Miranda Nisenon and Lysanne Larose. Along with the ceramic work, there was an Empty Bowls decorating event, open air jazz concerts, and puppet theater performances to enjoy at Canada’s largest outdoor ceramics event.



1 Eventgoers peruse the cup wall featuring hundreds of handmade vessels. 2 Busting booths featured the work of over 100 different ceramic artists on display. 3 Booths await throngs of admirers.

37th Annual California Conference for the Advancement of Ceramic Arts

- April 12–13, 2024
- Davis, California
- www.natsoulas.com
- The conference included work, demonstrations, and lectures by Lisa Clague, Morel Doucet, Sean Henry, Ah Leon, Lisa Reinertson, and Chris Theiss. Over 35 pop-up events and exhibitions featured works from students across Northern California including CSU Sacramento, Humboldt Polytechnic College, CSU San Francisco, California College of the Arts, UC Santa Cruz, CSU Chico, CSU San Jose State University, and many more.



4 Sean Henry's *Maquette for Sleeping Man*, 12 in. (30.5 cm) in height, ceramic, 2011.



5 Lisa Reinertson demonstrating outdoors at the 2024 conference.

Clay Fest

- June 22, 2024
- Philadelphia, Pennsylvania
- www.theclaystudio.org
- Hosted by The Clay Studio in Philadelphia, this annual celebration of community and clay featured free activities for all ages including hands-on clay projects, wheel-throwing demonstrations, a group sculpture extravaganza, artist-led projects by Delvin Goode and Brett Thomas, picture frame decorating, an ice cream social, and music. Concurrently, visitors could explore “50 Years in the Making,” an exhibition featuring the current work of over 150 alumni of The Clay Studio’s Resident Artist Program, Guest Artist Program, and Associate Artist Program over the 50 Years since its founding.



6



7



8

6 Lauren Mabry's *Glazescape (Molten Cloud)*, 16 in. (40.6 cm) in height, glaze, porcelain, 2024. 7 Brad Johnson's *Soft Square Cropped Jar*, 13 in. (33 cm) in height, salt-fired porcelain, 2024. 8 Clay Studio Guest Artist Delvin Goode led attendees in a handmade tile-decorating project, using custom stencils to create playful and energetic surfaces. All photos: *The Clay Studio*.

Sydney Craft Week

- October 6–15, 2023
- Sydney, Australia
- www.sydneycraftweek.com
- Sydney Craft Week is Sydney’s only city-wide festival dedicated to contemporary craft. With over 320 participating artists, 57 groups, and 152 events across 37 suburbs, it showcases exhibitions, workshops, markets, family-friendly activities, and more. The festival included the first MAKE Award: Biennial Prize for Innovation in Australian Craft, initiated by the Australian Design Centre, which was presented to ceramic artist Vipoo Srivilasa.



9

9 Throwing demo, Sydney Ceramics Market, 2023. Photo: Amy Piddington.

Midwest Pottery Fest

- April 13–14, 2024
- Kansas City, Missouri
- www.kcurbanpotters.com
- Kansas City Urban Potters presented the 2024 Midwest Pottery Fest at the Zhou B Art Center of Kansas City in the historic 18th and Vine District. The Midwest Pottery Fest includes a weekend pottery sale, free pottery demonstrations, and a flower bar. Kansas City Urban Potters are Bekah Bliss, Chandra DeBuse, Paul Donnelly, Jana Evans, Meredith Host, and Alex Watson. 2024 invited artists included: Andrew Castañeda, Emily Chamberlain, Dehmie Dehmlow, Lilly Powell, Joseph Rincones, and Momoko Usami.



1 Dehmie Dehmlow's *Oil Cans*, 10–13 in. (25.4–33 cm) in height, cone-6 red clay, terra sigillata, oxide washes, Mayco Stroke and Coat, and glaze, 2023. *Photo: Dehmie Dehmlow.*
 2 Left to right, front: Lilly Powell, Bekah Bliss, Dehmie Dehmlow, Momoko Usami, Paul Donnelly. Back: Chandra DeBuse, Alex Watson, Andrew Castañeda, Emily Chamberlain, Jana Evans, Joseph Rincones, and Meredith Host. 3 Meredith Host's *Dot Floral Print Bowls*, 6 in. (15.2 cm) in diameter, stoneware, decals, 2024. 4 Momoko Usami's *Butterfly Plate*, 8.5 in. (21.6 cm) in width, porcelain, 2024. 5 Lilly Powell's *Pinched Mugs*, 4.5 in. (11.4 cm) in height, dyed clay, underglaze pencil, glaze, 2023.

Firefest

- April 5–6, 2024
- Star, North Carolina
- www.starworksnc.org/firefest
- Attendees experienced live demonstrations, artist talks, hands-on workshops, and fiery finales with internationally recognized artists in ceramics, metal, and glass. In between events, guests enjoyed live music, food trucks, and gallery exhibitions. Featured Finnish ceramic artist Pekka Paikkari created a massive ceramic sculpture fired outside at Starworks, in a specially designed petal kiln.



6 Ceramic artist Pekka Paikkari chats with students during his demonstration. **7** After building and stacking Paikkari's work in a petal kiln in front of Starworks, it was fired and revealed to festival attendees. **8** Pekka Paikkari's *Stack*, 2024. **9** Jing Huang's *Loop #10*, stoneware, glaze, 2022. **10** Starworks Ceramics Intern Bo Gilbert instructs first-time students during a hands-on wheel throwing workshop during Firefest.

Salad Days

- April 13–14, 2024
- Newcastle, Maine
- www.watershedceramics.org
- Watershed Center for Ceramic Arts hosted its annual fundraising event, Salad Days, which featured nearly 500 dog-themed plates made by Salad Days Artist Jeremiah Ibarra. Guests waited in line for the highly-anticipated annual event and, after selecting a plate, were able to tour the Windgate Studio, watch live demonstrations, dine on a picnic lunch, and learn more about Watershed’s programming.



1



2



3



4

1 Guests browse and choose from hundreds of dog-themed plates at Salad Days. 2 Artist Alex Ferrante gives a live ceramics demonstration. 3 2024 Salad Days Artist Jeremiah Ibarra holds one of nearly 500 plates he created for the event. 4 Watershed co-founder Chris Gustin gives a tour of the Windgate Studio.

Silver City CLAY Festival 2024

- July 22–28, 2024
- Silver City, New Mexico
- www.clayfestival.com
- Silver City CLAY Festival goers were able to enjoy live demonstrations, concurrent exhibitions, community workshops, children’s activities, live music, and local foods. More than 15 local and visiting artists showcased functional and sculptural clay work honoring the Southwest tradition in the Clay Market. Demonstrating artists included Bede Clarke, Athena Steen, Scott Sutton, and Jared Tso.



5, 6 Students at the Three-Day Clay Wall Carving Workshop with Athena Steen at Whiskey Creek Zócalo. **7** Athena Steen guides students on best practices for carving designs into vertical surfaces. **8** Jared Tso workshop student Jasper Eyrich-Bingham working on a handbuilt vessel. **9** Headliner CLAY Festival artist Jared Tso teaching during the 1-week workshop at Western New Mexico University. Students pictured (left to right): Rachel Burke, Tanya Burns, Shane Burns, Hugh Remar, Liz Mikols, and Victor Vazquez-Garcia. **10** CLAY Festival closing reception for the national juried exhibition “From the Earth” and headliner artist exhibition “Alts’íísigí” by Jared Tso. Both shows were featured at Light Art Space Gallery. **11** Student in Athena Steen’s workshop preparing wall material.

pottery tours

Pottery tours, regional events, sales, visits with customers and fellow artists alike were a huge hit last spring, summer, and fall. So much so that artists are already back in the studio and event hosts are planning the next round of shows. Whether you are a first-time buyer, a trusted collector, or simply a curious neighbor, the following is a list of welcoming pottery tours, so you can start to plan your road trip. **Note: Please inquire with each tour for up-to-date information.**



1 16 Hands Studio Tour

16hands.com
October 19–20, 2024
6 Tour Stops | 13 Artists

2 Asparagus Valley Pottery Trail

asparagusvalleypotterytrail.com
April 26–27, 2025
8 Tour Stops | 29 Artists

3 Bayou City Clay Crawl

clayhouston.org/bccc
December 7, 2024
10 Tour Stops | 60+ Artists

4 Cannon River Clay Tour

cannonriverclaytour.com
August 17–18, 2024
4 Tour Stops | 23 Artists

5 Clay Collective Spring Pottery Tour

theclaycollective.net
May 4–5, 2024
10 Tour Stops | 29 Artists

6 Cracked Pot Studio Tour

crackedpotstudiotour.com
September 21–22, 2024
9 Tour Stops | 53 Artists

7 Durham County Pottery Tour

durhamcountypotterytour.com
November 9–10, 2024
20 Tour Stops | 27+ Artists

8 Hilltown 6 Pottery Tour

hilltown6.com
July 27–28, 2024
8 Tour Stops | 28 Artists

9 Hudson Valley Pottery Tour

hudsonvalleypotterytour.com
October 19–20, 2024
6 Tour Stops | 14 Artists

10 Lincoln Clay Tour

facebook.com/LincolnClayTour
May 13–14, 2023
3 Tour Stops | 14 Artists

11 Maine Pottery Tour

mainepotterytour.org
May 4–5, 2024
80 Tour Stops | 80 Artists

12 Michiana Pottery Tour

michianapotterytour.com
September 28–29, 2024
10 Tour Stops | 62 Artists

13 Omaha North Hills Pottery Tour

omahanorthhillspotterytour.com
October 5–6, 2024
4 Tour Stops | 20 Artists



14 **RVA Clay Tour**
rvaclay.com
 June 1–2, 2024
 21 Tour Stops | 100 Artists

17 **Seagrave Potters Fall Festival and Studio Tour**
discoverseagrave.com/events-all
 April 25–27, 2025
 50+ Tour Stops | 50+ Artists

15 **St. Croix Valley Pottery Tour**
minnesotapotters.com
 May 9–11, 2025
 7 Tour Stops | 65+ Artists

18 **Tampa Tour De Clay**
tampatourdeclay.com
 December 14–15, 2024
 3 Tour Stops | 11 Artists

16 **San Diego Pottery Tour**
sdpotterytour.com
 December 7–8, 2024
 15 Tour Stops + Online | 40+ Artists

19 **Twenty Dirty Hands Pottery Tour**
twentydirtyhands.com
 October 18–20, 2024
 7 Tour Stops | 25 Artists

*continued on
page 30*

large events in person and online in 2024–25

In addition to the pottery tours, several large in-person and online craft shows occur each year at a singular venue. Many of these events include not only sales of ceramic ware, but also demonstrations, lectures, and workshops. **Note: Please inquire with each event and venue for up-to-date information.**

47th Annual Philadelphia Museum of Art Craft Show

www.pmacraftshow.org/category/ceramics
November 15–17, 2024
In Person | 21 Ceramic Artists

Pottery on the Hill

potteryonthehilldc.org
November 15–17, 2024
In Person | 19 Artists

The Art School at Old Church: 49th Annual Pottery Show & Sale

oldchurchpotteryshow.org
December 6–8, 2024
In Person | 25 Artists

Smithsonian Craft Show

smithsoniancraftshow.org
April 23–25, 2025
In Person | 10+ Ceramic Artists

Flower City Pottery Invitational

flowercityarts.org
October 11–12, 2024
In Person + Online | 19 Artists

Spruce Pine Potters Market

www.sprucepinepottersmarket.com
October 12–13, 2024
In Person | 31 Artists

ADVANCER[®] KILN SHELVES

**SIZED FOR ANY
ELECTRIC KILN**

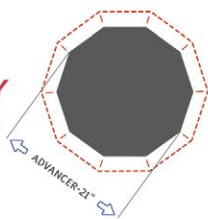

Often Imitated, Never Equaled

- Nitride-bonded, LO-MASS[®] kiln furniture
- 25+ years of proven performance
- Lightweight, thin and ultra strong
- Glaze resistant, <1% surface porosity
- Made flat to stay flat

 **KilnShelf.com**

 **SAINT-GOBAIN**

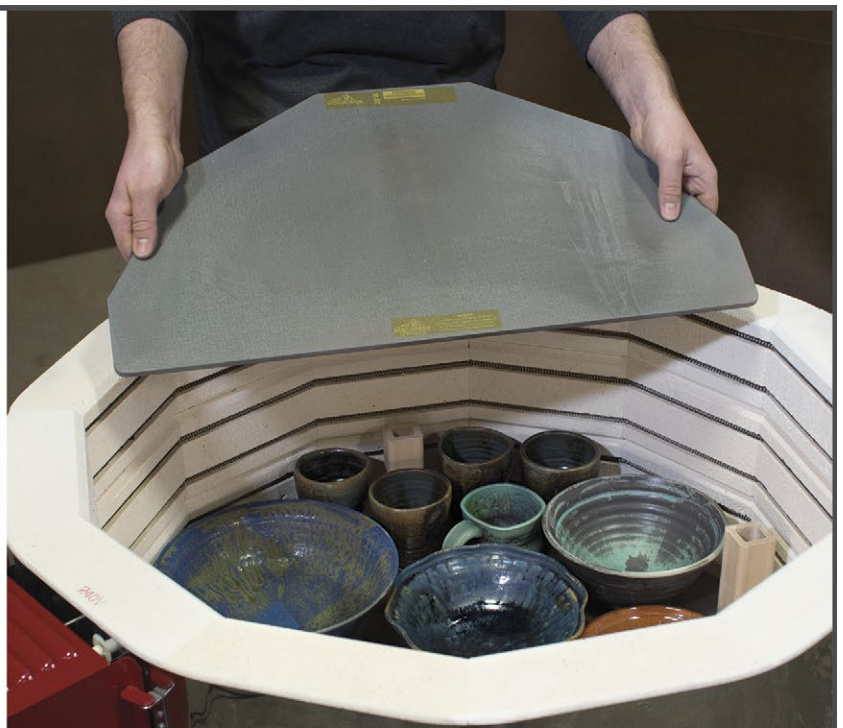

ORDER ONLINE OR CALL 866-545-6743





RUGGED CUSTOM CRAFTED MACHINES ENGINEERED FOR THE SERIOUS CERAMICIST



“We really love our Peter Pugger Mixing Pugmills. The addition of the VPM-30 model has been a game changer! My students are now able to create their own clay bodies to the creamy, smooth consistency they prefer. - Mike Helle, Lakeridge High School



■ BALL MILLS



■ MIXING PUGMILLS



■ KILNS



■ VACUUM
POWER
EXTRUDERS



■ STUDIO PRESS

Peter Pugger Mfg Inc

3661 Christy Lane, Ukiah, CA 95482
Phone: (707)463-1333 Fax: (707)462-5578

CE CERTIFIED

www.peterpugger.com

MADE IN THE USA

short-term resident artists

The ceramic artists included in this section have participated in residencies that are one year or less in duration.



1 Robyn Gibson's *Melee in the Mist*, 2024. Duration: July–August 2024. Residency: Mudflat Pottery School (www.mudflat.org), in Somerville, Massachusetts. 2 Carson Culp's platter, 2020. Duration: May–August 2024. 3 Kristy Moreno's *Juntas*, 2023. Duration: September–November 2024. 4 Christian Moses' *Untitled (B.B. Vase)*, 2024. Duration: January–March 2025. 5 Daniel Barragán's *Fountain 01-Jug 01*, 2024. Duration: January–March 2024. Residency: Greenwich House Pottery (greenwichhouse.org/pottery), in New York, New York.

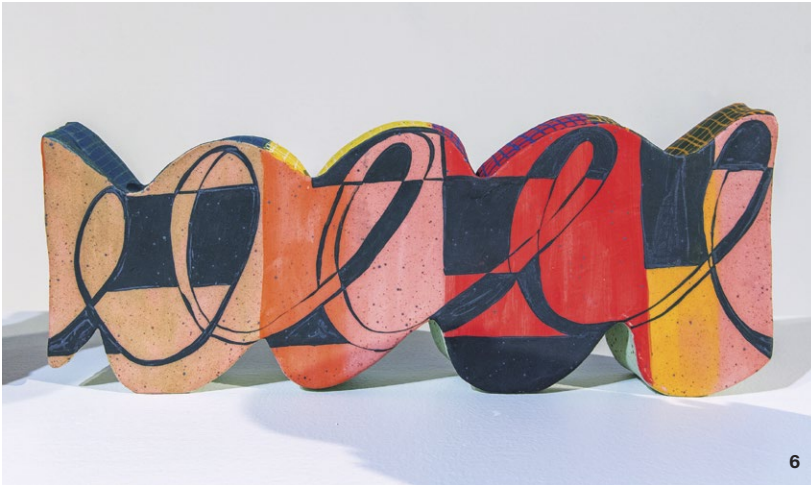

6



7



8



9



10

6 Corinna Cowles' *Loop Box*, 2024. Duration: June–August 2024. 7 Jason Lee Starin's *SOL 030*, 2023. Duration: June–August 2024. 8 Aida Lizalde's *No Oracles, No Gracias*, 2022. Duration: June–August 2024. 9 Priscilla Dobler Dzul's *Vessels of Knowledge, Tres*, 2022. Duration: June–August 2024. 10 Marcè Nixon-Washington's *Yellow Mudcloth Vase*, 2024. Duration: June–August 2024. Residency: Archie Bray (archiebray.org), in Helena, Montana. 6–10 Photos: *Floating Leaf Studios*. 11 Mike Cerv's *Plant Tub*, 2024. Duration: January–April 2024. 12 Heidi Schultz's *One With Everything Goblet*, 2024. Duration: May–August 2024. Residency: Belger Arts (belgerarts.org), in Kansas City, Missouri.



11



12



1 Tila Anttila's *Sempervirens*, 2024. Duration: July 2024. 2 Ginar Liu's *Corvo e Lupa*, 2024. Duration: April–May 2024. 3 Stacy Jo Scott's *But the Soul is Light* 2021, 2021. Duration: October 2024. 4 Walter O'Neill's *An About Face*, 2024. Duration: October 2024. 5 Marty Fielding's *Ombre*, 2024. Duration: July 2024. 6 Cori Crumrine's *La Lupa*, 2024. Duration: June 2024. 7 Kelsey Duncan's *Monolite Dormiente*, 2024. Duration: April–May 2024. 8 Dana Mufti's *Seeking Connections*, 2024. Duration: March–April 2024. 9 Yana Payusova's *Apparatus*, 2024. Duration: July 2024. Residency: C.R.E.T.A Rome (www.cretarome.com), in Rome, Italy. 1, 2, 5–9 Photos: Paolo Porelli.



10



11



12



13



15



14

10 Izanna Perry's *Lighthouse*, 2024. Duration: August 2023–July 2024. 11 Huey Lee's *Dino's Adventure*, 2024. Duration: August 2023–July 2024. 12 Allison Achtenhagen's vase, 2024. Duration: August 2023–July 2024. Residency: KC Clay Guild (kcclayguild.org), in Kansas City, Missouri. 13 Ashley Banegas' *Darlene*, 2024. Duration: November 2023–August 2024. Residency: Carbondale Clay Center (www.carbondaleclay.org), in Carbondale, Colorado. 14 Breana Ferreira's *A Collection of Cups*, 2024. Duration: June 2024–May 2025. 15 Marissa Childers' *Daily Rituals*, 2023. Duration: June 2023–May 2024. Residency: Arrowmont School of Arts and Crafts (www.arrowmont.org), in Gatlinburg, Tennessee.



1 Chloe Begg's *Three-Piece Stacked Form*, 2024. Duration: January–February 2024. 2 Gayle Uyagaqi Kabloona's *Faces faces faces*, collaboration with Joel Nichols, 2024. Duration: May–June 2024. 3 Béatrice Côté's *Salty green & pink gradation*, 2024. Duration: January–February 2024. Residency: Banff Centre for Arts and Creativity (www.banffcentre.ca), in Banff, Alberta, Canada. 4 Joon Hee Kim's *Love Wins*, 2024. Duration: April–June 2024. 5 Ellen Kleckner's *Wedding Broom*, 2024. Duration: April–June 2024. 6 Larry Buller's *Obey Daddy*, 2024. Duration: January–March 2024. Residency: Northern Clay Center (northernclaycenter.org), in Minneapolis, Minnesota. 7 Richard Conti's espresso cups, 2024. Duration: January–March 2024. Residency: Truro Center for the Arts at Castle Hill (www.castlehill.org), in Truro, Massachusetts.



8



9



10



11



12



13



14



15



16

8 Margaret Howton's *On the Cusp*, 2024. Duration: December 2023–January 2024. 9 Jay Schmidt's *Deep Fake*, 2024. Duration: February–March 2024. 10 Denny Gerwin's *Figure Vessel*, 2024. Duration: April 2024. 11 Beth Korth's *Knotted Head Over Hooves- Stirred Movement Surrounded by Blurred Colors and Shapes as Only My Force Forward is Focused In While My Feet are Dizzy in All Directions*, 2024. Photo: Josef Peters. Duration: April–May 2024. 12 Jason Hess' bowl, 2024. Duration: September–October 2024. 13 Erika Van Kirk's *Frost Cups*, 2024. Duration: February–March 2024. 14 Mandy Henebry's *Nesting Pitcher Set with Cups*, 2024. Duration: February–March 2024. 15 Ana Busto's *She/They*, 2024. Duration: December 2023–January 2024. 16 John Gargano's *Tengai To Denver*, 2024. Duration: January–March 2024. 17 Marret Metzger's *Midnight Moth Moon Jar*, 2024. Duration: February–March 2024. 18 Michael Lemke's teapot, 2024. Duration: January 2024. Residency: Red Lodge Clay Center (www.redlodgeclaycenter.com), in Red Lodge, Montana.



17



18



1 Bailey Holley's *Kissing and Screaming*, 2024. Duration: June–September 2024. 2 Kashima Robinson's *A Hill to Thrive On*, 2023. Duration: September 2024–August 2025. 3 Tracy Wilkinson's *KALA*, 2024. Duration: March–May 2024. 4 Riho Kawachi's *Flowers*, 2024. Duration: June–August 2024. 5 Shea Kister's *Ongoing Arguments*, 2024. Duration: September 2024–August 2025. 6 Veronica Walton's *Together*, 2024. Duration: September 2023–January 2024. 7 Annie Braunschweig's untitled, 2024. Duration: September 2024–February 2025. 8 Kristyn Rohrer's *Bitch I Said What I Said, I Don't Care I'll Paint the Town Red*, 2024. Duration: September 2024–August 2025. 9 Ali Saunders' *Yellow Pattern Plates*, 2023. Duration: September 2024–August 2025. 10 Patrick Bell's *Enigmatic Pathology (blue and pink)*, 2024. Duration: September 2024–August 2025. Residency: Baltimore Clayworks (baltimoreclayworks.org), in Baltimore, Maryland.





11 Tatum Ernst's *Home*, 2024. Duration: May–August 2024. 12 Cori Crumrine's *Dark Luck*, 2023. Duration: July 2024. 13 Avi Farber's *Falling Rain*, 2022. Duration: June 2024. 14 Juree Kim's *Evanescent Landscape—Philadelphia Rowhouse*, 2023. Courtesy of The Clay Studio. Duration: September–December 2024. 15 Fletcher Henderson's *Hive*, 2023. Duration: May–August 2024. Residency: The Clay Studio of Missoula (www.theclaystudioofmissoula.org), in Missoula, Montana. 16 Chad Curtis' *Natural Codes: Constraints and Iterations 24.01.24*, 2024. Courtesy of The Clay Studio. Duration: January 2024. Residency: The Clay Studio (theclaystudio.org), in Philadelphia, Pennsylvania.



SCOTT CREEK EXTRUDERS



"The most overlooked tool in the potter's studio"
 -Charan Sachar

Can you make everything with a clay extruder rendering your wheel obsolete? That's exactly what Charan Sachar did. Charan's entire workflow is based around extruded forms utilizing The Scott Creek Pottery 5" Wall Mount Extruder. After struggling to produce enough work on the wheel, he came to the conclusion that the speed, efficiency and consistency of the extruder was right for him.

Quite simply a Scott Creek Extruder is the best way to work smarter, not harder. Whether you're using our premade dies to extrude dozens of handles or making cylinders in bulk, we've got you covered.

Scott Creek Pottery is the home of the Original Super Duper Clay Gun, XL Clay Gun and 4" & 5" Wall Mount extruders. Accept no substitute!

View more of Charan's work and explore the possibilities at www.creativewithclay.com

**2636 Pioneer Way East
 Tacoma, WA 98404
www.scottcreekpottery.net**



AARDVARK
Clay & Supplies
Need it? Got it.

Clay, Glazes, Tools, Underglazes, Brushes,
 Bats, Stains, Raw Materials, Equipment,
 Kilns & Firing Accessories 714-541-4157
www.AardvarkClay.com

DSP01
Drainable Splash Pan

Chinese Clay Art US
www.ChineseClayArt.com
 1-800-689.Clay(2529)
ChineseClayArt@hotmail.com

Note: This Drainable Splash Pan should fit many different name brand pottery wheels, but before placing your order, please measure the size of your pottery wheel, and test if your pottery wheel can be removed.

4.33"/110mm
 4.72"/120mm
 8.35"/200mm
 16.54"/420mm
 18.9"/480mm

Not included

Installation tool (not included)
 Long Arm Hexagon Wrench 4mm or 8mm depending on what type of pottery wheels

Installation Instructions

1. Remove old splash pan and remove wheel head
2. Use Velcro strips to attach drainable splash pan, making sure the pan is centered
3. Reinstall the wheel-head and tighten the screw with the hexagon wrench

Patent No. 202420712715.9 China, International Patent Pending



**Need the perfect kiln?
Don't worry we have you covered...**



**There's more where this came from
Call or email for a catalog or more info!**

4736 Convair Drive Carson City, Nevada 89706 Email: Info@cressmfg.com Fax: 775-884-2991 Phone: 775-884-2777



ARROWMONT

SCHOOL OF ARTS AND CRAFTS

A Place, An Opportunity, An Experience.

Arrowmont.

Weekend, One-Week and Two-Week Clay Workshops in figurative, functional, atmospheric, and more.

REGISTER NOW AT ARROWMONT.ORG OR CALL 865-436-5860

Enriching Lives Through Art and Craft



THE DEX TOOL

AVAILABLE IN 5 DUAL ENDED STYLES



awards

Center for Craft Grants and Fellowships

Each year, the Center for Craft awards a variety of grants and fellowships to artists in craft media. In 2024, several ceramic artists were selected for these awards.

Jacqueline Bishop was selected for a Craft Research Fund, which provides up to \$15,000 to support new and interdisciplinary craft research. Hana Foo was selected for a Windgate-Lamar Fellowship, which awards \$15,000 to ten undergraduate seniors for their skill in craft. Carolyn Hazel Drake, Yoonjee Kwak, and Eun-Ha Paek were selected for the Teaching Artist Cohort, which provides \$10,000 grants to 21 teaching artists and a supportive 8-month cohort experience. For more information about the Center for Craft Grants and Fellowships, visit www.centerforcraft.org/grants-and-fellowships.

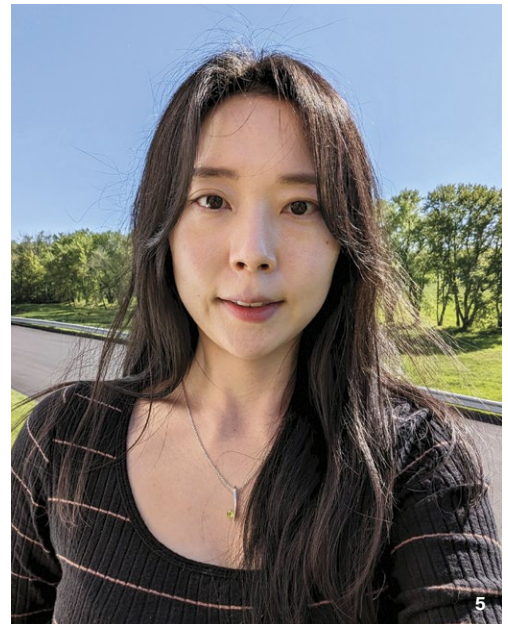

1 Jacqueline Bishop. 2 Hana Foo. Photo: Luis Godinez.
3 Carolyn Hazel Drake. Photo: Michael Brooks. 4 Eun-Ha Paek. Photo: Karl Ackermann. 5 Yoonjee Kwak.

James Renwick Alliance for Craft's Master of the Medium Award

The James Renwick Alliance for Craft's (JRACraft) Master of the Medium Award recognizes artists working in the five craft areas of ceramics, fiber, glass, metal, and wood. Artists are selected for their demonstrated excellence in craftsmanship, influence in their media, and contributions to the field of craft. Steven Young Lee was selected as one of the awardees in 2024 for his ceramic work and practice. For more information visit www.jracraft.org.



6 Steven Young Lee's *Shattered Dreams and Movements of Change*, 12.5 ft. (3.8 m) in length, porcelain, cobalt oxide, copper oxide, glaze, fired to 2300°F (1260°C), epoxy resin, gold leaf, 2023. Photo: Barclay Hughes. 7 Steven Young Lee, shown on May 4, 2024, in Washington, DC, with his Master of the Medium Award at the Spring Craft Weekend Gala. Photo: Elena Volkova.



Jerome Ackerman Endowed Internship

The Jerome Ackerman Internship takes place at the Alfred Ceramic Art Museum. This is a paid internship offered to undergraduate students from the Alfred University's School of Art and Design. The internship is designed to further an intern's professional goals and includes working directly with the museum's curator and director while helping to address its organizational needs.

In fall 2023, the internship was awarded to Diabou Hubbard. In spring 2024, Emily Woo was awarded the internship. For more information visit www.alfred.edu.



8 Diabou Hubbard, Jerome Ackerman Intern, spring 2024. 9 Emily Woo Alfred, Jerome Ackerman Intern, fall 2023.

Northern Clay Center (NCC) awards several grants and residencies to individuals each year. Here's a look at the artists who received awards in 2024. For more information about the Northern Clay Center grants, visit northernclaycenter.org/artist-services/grants-for-artists.

Pottery Museum of Red Wing Award

This cash award of \$1000 recognizes one early-career Minnesota artist pursuing a career pottery or historical studies of the pottery industry. The 2024 recipient was Ivy Mattson.



1 Ivy Mattson. 2 Ivy Mattson's *Blooming Flower Basket*, porcelain, 2023.



3 Car Riegger.

Warren MacKenzie Advancement Award (WMAA)

This award is available to students and emerging artists to further their research and education, and provides a cash award of up to \$2000. In 2024, Car Riegger was recognized with this award.

Early Career Artist Residencies

The Early Career Artists Residencies are awarded to up to four artists and are comprised of the Anonymous Artist Studio Fellowship and the BIPOC Studio Fellowship. The fellows are provided with a furnished studio and material and firing stipends. In 2024, Jessica Hernandez and Hannah Kautto were awarded the Anonymous Artist Studio Fellowship, and Khalil Jannah was awarded the BIPOC Studio Fellowship.

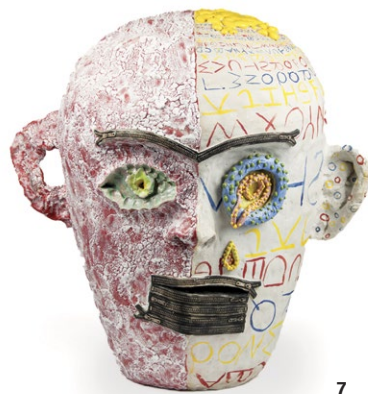

4 Jessica Hernandez. 5 Jessica Hernandez' *Cnidaria Tubastraea Coccinea, Anthozoa Series*, 14.5 in. (36.8 cm) in height, ceramic, 2021. 6 Hannah Kautto. 7 Hannah Kautto's *Whispers*, 22 in. (55.9 cm), in height, cone-6 stoneware, 2023. 8 Khalil Jannah. 9 Khalil Jannah's *Space Bishop to E5*, 27 in. (68.6 cm) in height, cone-6 stoneware, slip, 2024.

McKnight Artist Fellowship for Ceramic Artists

The McKnight Artist Fellowship for Ceramic Artists supports Minnesota ceramic artists. Two \$25,000 grants are awarded annually. The recipients will also be featured in a workshop and an exhibition. The 2024 recipients are Ani Kasten and Maggie Jaszczak.



10



11



12



13

10 Ani Kasten. 11 Ani Kasten's *Loose Curls*, 13 in. (33 cm) in height, wheel-thrown and altered black stoneware and porcelain, slips, glazes, nichrome wire, fired in oxidation to cone 6, 2024. 12 Maggie Jaszczak. 13 Maggie Jaszczak's *Candle Holders for 3 Candles*, 14 in. (35.6 cm) in height, handbuilt earthenware, slip, underglaze, glaze, fired to cone 04 in an electric kiln, 2023.

McKnight Residency for Ceramic Artists

This residency provides studio space and a \$6000 award to up to eight mid-career artists (non-residents of Minnesota). In 2024, the following artists were selected: Birdie Boone, Uriel Caspi, Sana Musasama, Dorothea Nold, and KyoungHwa Oh.

14 Birdie Boone. 15 Uriel Caspi. 16 Sana Musasama. 17 Dorothea Nold. *Photo: Moran Shavit.* 18 KyoungHwa Oh.



14



15



16

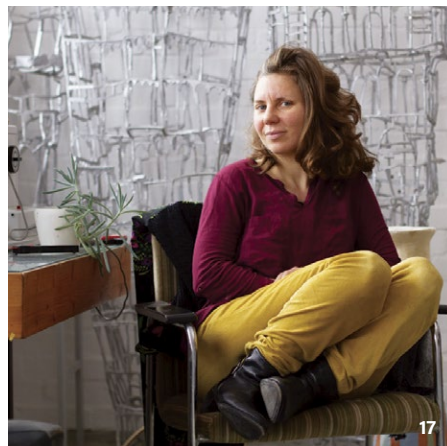

17



18

Van Achterbergh Prize 2024

The Van Achterbergh-Domhof Foundation recognized the Galerie Terra Delft with the Van Achterbergh Prize 2024 for its tremendous contribution to the ceramics arts in the Netherlands. The award includes €15,000 (\$16,625) monetary prize and is granted every two years. For more information visit www.vanachterbergh.nl.



1 Galerie Terra Delft, interior, with the founders Simone Haak (left) and Joke Doedens (right).
2 Ann Van Hoey's two bowls. 3 Felicity Aylieff's porcelain vase in blue and white.

National Endowment for the Arts Organizational Grants

The National Endowment for the Arts (NEA) grants have been awarded to numerous organizations in 2024 for support of programming involving ceramics.

- Archie Bray Foundation in Helena, Montana, received \$30,000 to support a visiting artist program in ceramics.
- Armory Center for the Arts in Pasadena, California, received \$30,000 to support the exhibition, "From the Ground Up: Nurturing Diversity in Hostile Environments," and an accompanying publication.
- Bowling Green State University in Bowling Green, Ohio, received \$25,000 to support an exhibition featuring ceramic and non-ceramic artists.
- Clay Studio in Philadelphia, Pennsylvania, received \$25,000 to support an exhibition featuring the work of contemporary South African artists.
- Clay Studio of Missoula in Missoula, Montana, received \$11,000 to support a ceramic arts after-school program.
- Creativity Explored in San Francisco, California, received \$40,000 to support art programming and professional development opportunities with a focus on artists with developmental disabilities.
- Haystack Mountain School of Crafts (Haystack) in Deer Isle, Maine, received \$30,000 to support a digital fabrication residency for craft artists.
- Honolulu Biennial Foundation in Honolulu, Hawaii, received \$50,000 to support the Hawaii Triennial 2025, an arts festival including an exhibition and educational programming.
- Houston Center for Contemporary Craft in Houston, Texas, received \$25,000 to support a series of community-based craft educational programs.
- Kearny Street Workshop in San Francisco, California, received \$20,000 to support an exhibition series and residency program for artists of the Asian Pacific American diaspora.
- Kemper Museum Operating Foundation (Kemper Museum of Contemporary Art) in Kansas City, Missouri, received \$40,000 to support the exhibition, "Smoke Gets in Your Eyes: Forging Relationships Through Ceramics."
- Korean Cultural Center of Chicago in Wheeling, Illinois, received \$30,000 to support an exhibition of contemporary Korean ceramics.
- Leedy Foundation in Kansas City, Missouri, received \$35,000 to support an exhibition and public programming about women's experiences as both artists and mothers.
- Main Line Art Center in Haverford, Pennsylvania, received \$20,000 to support a series of mentoring residency programs and an exhibition featuring work by ceramic artist Roberto Lugo.
- National Council on Education for the Ceramic Arts (NCECA) in Boulder, Colorado, received \$80,000 to support exhibitions and educational programming for an annual conference on the ceramic arts.
- Philadelphia Mural Arts Advocates (Mural Arts Philadelphia) in Philadelphia, Pennsylvania, received \$30,000 to support development of a public art project by ceramic artist Roberto Lugo.
- Scottsdale Arts in Scottsdale, Arizona, received \$50,000 to support a visual arts exhibition highlighting issues faced by women, queer, and transgender people.
- The Oxbow in Saugatuck, Michigan, received \$50,000 to support an artist residency program.
- Watershed Center for the Ceramic Arts (Watershed) in Newcastle, Maine, received \$35,000 to support a mentor and mentee artist residency program.

MKM POTTERY Tools

New MKM Rollers!



BHR-158 (12cm)



RL-044 (6cm)



RL-045 (6cm)



BHR-159 (12cm)



**P: (920) 903-8918 www.mkmpotterytools.com
 E: orders@mkmpotterytools.com Order MKM Products Online**

 **Standard**
Clay Company

▲6 214 Scott's Red



The studio standard.



Immersive Workshops
Private Group Firings
Community Classes
Online Workshops + Demos
Residencies & Assistantships
A close drive from
NYC or Philly

PETERS VALLEY

SCHOOL OF CRAFT

19 Kuhn Road, Layton, NJ 07851
(973) 948-5200

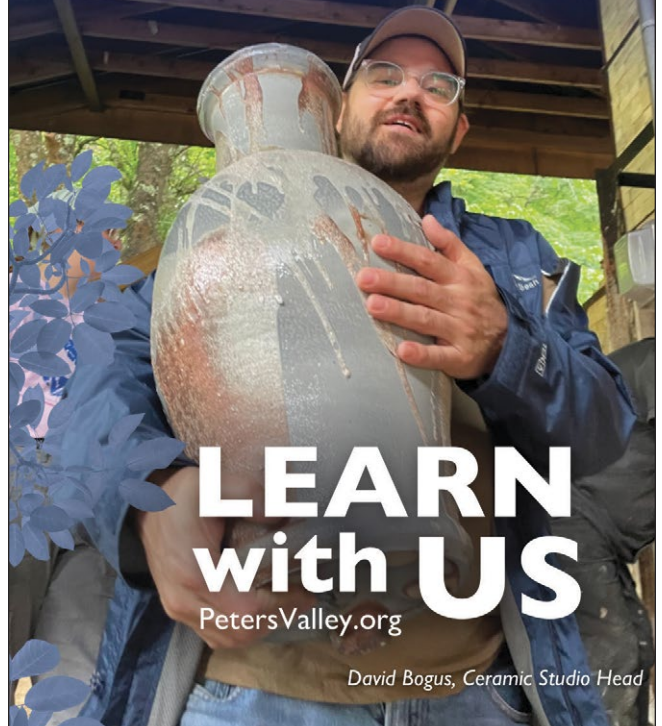

LEARN
with US

PetersValley.org

David Bogus, Ceramic Studio Head

icons remembered

Jack Earl

1934–2023

Jack Earl was born outside of the small town of Uniopolis, Ohio. He took an early interest in drawing and painting as a child, and after taking high school art classes, decided to pursue a career as an art teacher. He received his BA from Bluffton College in 1956 where he was introduced to ceramics. After teaching high school and grade school for seven years, he pursued an MA in ceramics at The Ohio State University. He continued his teaching career, working as an instructor at the Toledo Museum of Art and as an associate professor at Virginia Commonwealth University until 1978, before he and his family packed up and found a new home in Lakeview, Ohio.

Jack was known for his philosophical and whimsical, figurative porcelain work that reflected his outlook growing up and living in the Midwest. He was the first artist in residence at the Kohler Company. Jack also authored a book of poems and stories, *Just For The Fun Of It*. His ceramic work is displayed across the world, including in the Smithsonian Museum.

—Sourced from www.hanssoneelyallison.com.

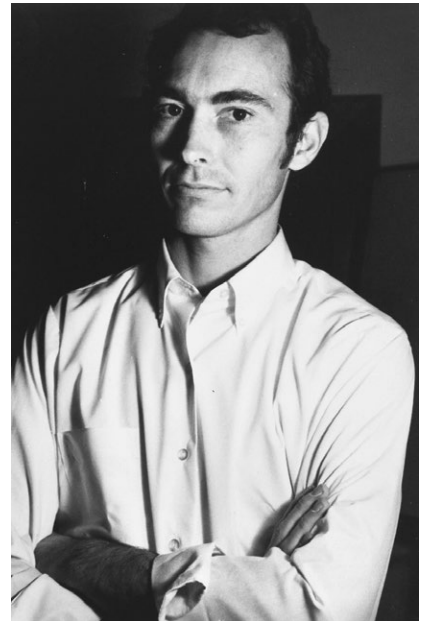

Marsha Owen

1954–2023

Marsha, a native of Mississippi, felt fortunate to live in North Carolina, a center of craft pottery production. She took her first pottery course at the North Carolina State University (NCSU) Craft Center in 1975 and knew immediately that she had found her vocation. She honed her skills and broadened her expertise to include almost any utilitarian object that could be made in clay. In 1993 her husband, Rick Moss, joined her adding his handbuilding and surface decoration skills, as well as carrying out any necessary business chores. Marsha loved her work. She leaves behind her husband and many, many friends and fellow potters.

—Sourced from marshaowenpottery.com. Photo: Courtesy of Robin Dreyer.

Patrick Dougherty

1951–2023

Patrick earned a BFA from Northern Kentucky University and he went on to earn an MFA from Clemson University. He taught ceramics at the collegiate level for six years, at the former Edgecliff College of Xavier University, and later at Northern Kentucky University.

After teaching, Patrick became a self-employed studio potter for over 30 years. He taught numerous ceramic workshops and worked with teens with disabilities at the Point/Arc of Northern Kentucky. He also studied and created architectural ceramics for locations across the US. He became Vice-President/Art, Design, and Development at Rookwood Pottery in 2011 for a brief time. His studio is located at Queen City Clay, in Norwood, Ohio, and will remain in use as an educational space for architectural ceramics and for visiting artists in residence.

Patrick's work was recognized nationally in more than 25 books and periodicals, including "Smithsonian Magazine," "American Craft," and "Masters of Earthenware." Patrick received over 35 awards for his work and his pieces have appeared in over 100 exhibits, including the prestigious Smithsonian Craft Shows of 2005 and 2009.

—Sourced from [Legacy.com](https://www.legacy.com) by Serenity Funeral Care.



Jerry Chappelle

1939–2024

Jerry Chappelle was born in Fredericktown, Missouri. He graduated from Murray State University with an undergraduate degree in art and went on to pursue a Master's Degree from the University of Minnesota.

In 1970 Jerry, his wife Kathy, and their three children moved from Minnesota to Georgia where he accepted a position teaching ceramics at the University of Georgia and started Happy Valley Pottery. In 1976, Jerry left teaching at the University of Georgia and he and his wife worked full time producing pottery and attending the ACC (American Craft Council) shows. Jerry played a large role in developing the arts in Georgia, especially Watkinsville, Oconee County, Georgia, where he was one of the founders of the Oconee Cultural Arts Foundation. Additionally, he served on the board of several art organizations in and out of Georgia.

The Chappelles were world-renowned artists and have been featured in hundreds of magazines and newspapers. Their successful pottery business was in operation for 54 years.

—Courtesy of Kathy Chappelle.

Spencer Davis

1924–2024

Spencer attended Miami University in Oxford, Ohio, until he was called to serve in World War II. Before deployment he married Betty Jane Emery. Spencer returned to Ohio, and graduated from the College of Commerce and Administration at The Ohio State University in 1948. After graduation he joined The American Ceramic Society as assistant secretary. There he saw a need for a trade magazine, and in 1952 he became cofounder and publisher of *Ceramics Monthly* magazine. A few years later he became the sole owner of the world’s premier publication for ceramic artists and potters. In 1996 Spencer retired and was looking for the right home for his magazine and its staff and sold *Ceramics Monthly* to The American Ceramic Society, located in Westerville, Ohio.

—Sourced from www.dignitymemorial.com.

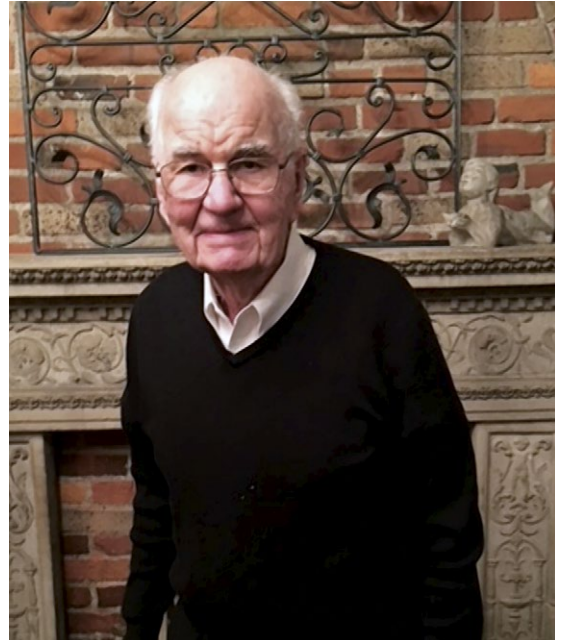

Mishima Kimiyo

1932–2024

Mishima was one of the most prominent and widely exhibited of the first generation of Japanese women artists who used clay as a medium. Her realistic depictions of discarded newspapers, print materials, cardboard containers, and other refuse were metaphors for the “throwaway” nature of contemporary mass media.

Born in Osaka, Mishima was first a painting student in Tokyo, but after her marriage to Mishima Shigeji, she returned to Osaka. In the 1970s, she developed an interest in silk-screening such “informational” materials to create sculptures formed from clay. As a result of receiving a Rockefeller Grant in 1986-87, the art scene in New York became an influential part of her development. Her work continued to evolve, and her witty, metaphorical sculptures were exhibited internationally. Today Mishima’s sculptures are found in museum collections around the world. In 2021 she was awarded the Gold Prize for lifetime achievement by the Japan Ceramic Society. Her career was recently the focus of a retrospective exhibition at the Nerima Art Museum and is currently featured in the American touring exhibition, “Radical Clay—Contemporary Women Artists from Japan.”

—Sourced from *Joan B Mirviss LTD.*

Anne Mossman

1952–2024

Anne lived in the Gold Coast of Australia. Her ceramics journey began in 2003 after studying at the Australian National University for an Advanced Ceramic Diploma. She worked in the Japanese nerikomi technique of colored and layered clays and developed her own library of colors over many years.

Anne was the recipient of several national ceramic awards and has work in private and public collections. She enjoyed community involvement in the form of teaching, workshops, and participation in ceramic associations.

—Sourced from www.annemossman.com.



Elaine Levin

1926–2024

Elaine made a big impact on the ceramic community as an art historian, writer, lecturer, and curator. Elaine’s deep knowledge of ceramics and her passion to illicit interest in its history made her a beloved teacher. Her ambitious book, *The History of Ceramics: From Pipkins and Bean Pots to Contemporary Forms, 1607 to the Present*, was published in 1988. It was a comprehensive survey of American pottery covering folk art, the Arts and Crafts movement, Art Deco, Abstract Expressionism, and Post-Modernism. She also was a contributor to *Ceramics Monthly*.

—Sourced from AMOCA’s *Adjunct Curator*, Jo Lauria, and Karen Koblitz.

new media

BOOKS

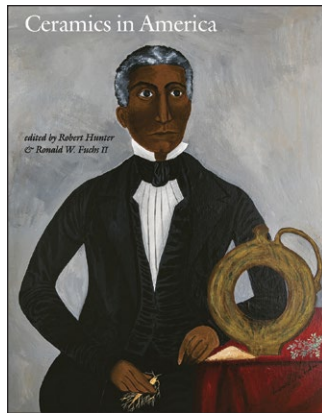

Ceramics in America

Edited by Robert Hunter and Ronald W. Fuchs II

Comprised of essays on a variety of topics relating to American ceramic history, this volume delves deep into stories about art, culture, and impact. 240 pages, *Chipstone Foundation, Wisconsin, 2024. ISBN 978-1737717522. chipstone.org/issue.php/55/Ceramics-in-America-2023*

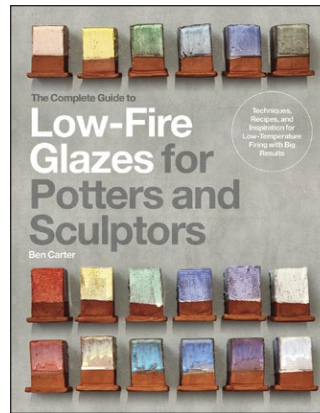

The Complete Guide to Low-Fire Glazes for Potters and Sculptors

by Ben Carter

Ben Carter, author and potter, shares the benefits, techniques, tips, and recipes for successful firings at low temperatures. 176 pages, *Quarry Books, an imprint of The Quarto Group, Beverly, Massachusetts, 2024. ISBN 978-0760385845. www.quarto.com/books/9780760385845/the-complete-guide-to-low-fire-glazes-for-potters-and-sculptors*

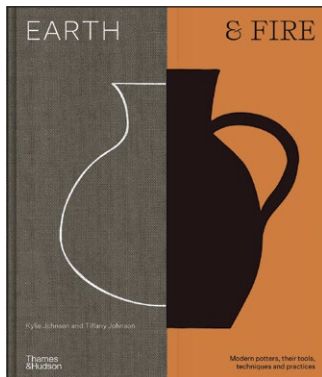

Earth and Fire: Modern Potters, Their Tools, Techniques, and Practices

by Kylie Johnson and Tiffany Johnson

This book provides unique insight into the work and practices of 45 ceramic artists, including their challenges, material research, and varied approaches to clay. 272 pages, *Thames & Hudson, New York, New York, 2023. Photo: Courtesy of Thames & Hudson. ISBN 9781760763749. paperboatpress.com*

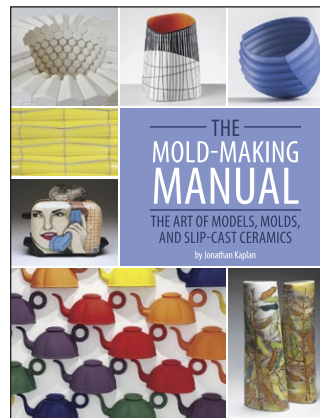

The Mold-Making Manual: The Art of Models, Molds, and Slip-cast Ceramics

by Jonathan Kaplan

Pulling from over five decades of experience working with ceramics, slip casting, and plaster work, Jonathan Kaplan provides this extensive guide to mold-making and slip-cast ceramics. 260 pages, *The American Ceramic Society, Westerville, Ohio, 2024. ISBN 978-1-57498-398-2. ceramicartsnetwork.org/shop*

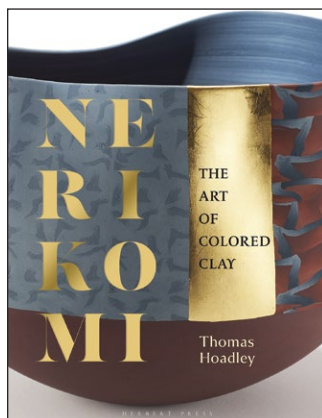

Nerikomi: The Art of Colored Clay

by Thomas Hoadley

Inspired by the beauty and unlimited possibilities of incorporating color into clay, this book examines the history, process, and myriad applications of the nerikomi technique. 192 pages, *Herbert Press, London, UK, 2024. ISBN 9781789941692. www.bloomsbury.com/us/nerikomi-9781789941692*

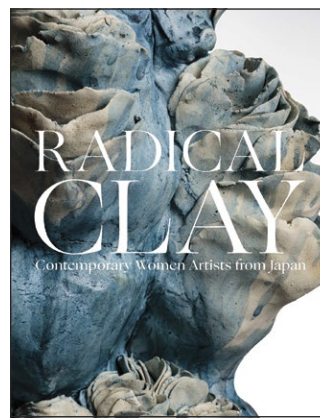

Radical Clay: Contemporary Women Artists from Japan

Edited by Joe Earle

This catalog highlights 36 contemporary Japanese female artists (from the last 50 years) making innovative and successful ceramic artwork, and the context in which they create. 128 pages, *Art Institute of Chicago, Chicago, Illinois, 2023. ISBN 9780300273236. shop.artic.edu/products/289047?_pos=1&_sid=42a82e9cb&_ss=r*

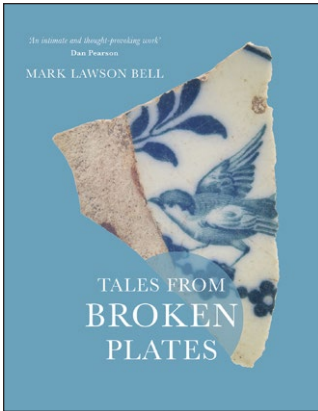

Tales from Broken Plates

by Mark Lawson Bell

Artist and collector Mark Lawson Bell imagines the stories behind 52 shards of pottery. 162 pages, Mark Lawson Bell, UK, 2023. ISBN 978-1915406064. www.talesfrombrokenplates.com



Unearthed

Published by the Nora Eccles Harrison Museum of Art

Comprised of numerous essays and illustrated biographies on over 200 artists, this book outlines the contents, variety, and legacy of Nora Eccles Treadwell Harrison's collection of American ceramics. 304 pages, University Press of Colorado, Colorado, 2024. ISBN 978-1-64642-634-8. upcolorado.com/university-press-of-colorado/item/6596-unearthed

PODCASTS

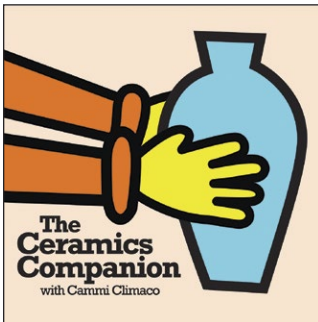

The Ceramics Companion

Hosted by Cammi Climaco

Podcast host Cammi Climaco sits down with fellow ceramic artists to discuss topics relevant to working artists, from business skills to gate-keeping. www.cammiclimaco.com/the-ceramics-companion



The Ceramics Podcast

Hosted by Cammi Climaco and Gustav Hamilton

This podcast provides a light-hearted look into all things clay and contemporary ceramics. Hosts Cammi Climaco and Gustav Hamilton interview an artist in each episode and conversations cover a range of topics. www.cammiclimaco.com/theceramicspodcast

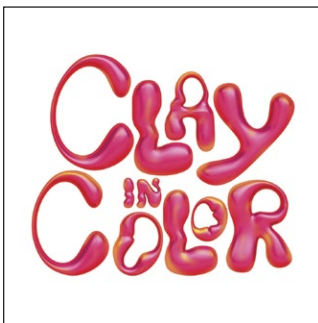

Clay in Color

Hosted by Angelik Vizcarrondo-Laboy and Alex Anderson

Curator Angelik Vizcarrondo-Laboy and ceramic artist Alex Anderson discuss contemporary ceramics and interview an artist or professional of color about their work in this podcast. 18 episodes per year, updated bi-weekly, The Brickyard Podcast Network. www.brickyardnetwork.org/clayincolor



Colour and Ceramics

Hosted by Bob Acton

Through interviews with contemporary ceramic artists, host Bob Acton explores the significance, application, and role of color in ceramics and how it is used as a means of communication. Updated bi-weekly. bobactonceramics.com/podcast/colourandceramics

PODCASTS (continued)



For Flux Sake

Hosted by Matt Katz, Rose Katz, and Kathy King

By applying decades of experience with knowledge of ceramic engineering and contemporary clay from Matt and Rose Katz and Kathy King, this podcast demystifies ceramic chemistry by answering listener-submitted questions. *24 episodes per year, updated bi-weekly, The Brickyard Podcast Network.* www.brickyardnetwork.org/forfluxsake



The Kiln Sitters

Hosted by Marianne Chénard, Brendan Tang, and Carole Epp

This podcasts explores contemporary Canadian ceramics for its vibrancy and diversity. Artists and hosts Marianne Chénard, Brendan Tang, and Carole Epp interview artists on their work and practices. *12 episodes per year, updated weekly, The Brickyard Podcast Network.* www.brickyardnetwork.org/thekilnsitters



The Maker's Playbook

Hosted by Rebecca Ickes Carra

Sharing interviews with artists and makers plus insights from Rebecca Ickes Carra's experience as an entrepreneur, this podcast provides a look into the reality of making a living through handmade objects. *30 episodes per year, The Brickyard Podcast Network.* www.makersplaybook.com



The Shot Callers

Hosted by Virgil Ortiz and Justin Reese

Artists Virgil Ortiz and Justin Reese and the podcast's guest make a signature cocktail while discussing clay and their paths in ceramics. *12 episodes per year, updated weekly, The Brickyard Podcast Network.* www.brickyardnetwork.org/theshotcallers



Tales of a Red Clay Rambler

Hosted by Ben Carter

Since 2012, artist and podcast host Ben Carter has conducted compelling interviews with contemporary clay artists to discuss their lives, studio practices, and the routes they have taken to get where they are with ceramics. *48 episodes per year, updated weekly, The Brickyard Podcast Network.* www.talesofaredclayrambler.com



Trade Secret

Hosted by Adam Chau

Artist and curator Adam Chau interviews two artists on a central theme in each episode of this podcast in order to share experiences and perspectives. *12 episodes per year, updated weekly, The Brickyard Podcast Network.* www.brickyardnetwork.org/tradeseecret

Ceramic Arts Network, 550 Polaris Parkway, Suite 510, Westerville, Ohio 43082

To subscribe to *Ceramics Monthly* magazine, please complete this form. Mail the completed form to us with check payment (DO NOT send cash). If paying by credit card (see below), you can mail or fax this form to us. Thank you!

Step 1: Please provide your email* address: _____
*Required: We cannot process your subscription without a contact email

Step 2: If you already have a subscription and want to renew, please write your Subscriber ID number in the boxes below. Your Subscriber ID is the 7-digit number that appears above your name on the magazine mailing label (see below). *If you don't already have a subscription, you can skip this step.*

Your magazine mailing label

 2703068 ← Your subscriber ID Your Name 123 Main Street PKD96708 Anytown, NY 00000 PO338 341-CERA1 001448183	<table border="1"> <tr> <td> </td><td> </td><td> </td><td> </td><td> </td><td> </td><td> </td> </tr> </table>							

Note: Red arrows in the original image point from the subscriber ID '2703068' to the first seven boxes, and from the 'PKD96708' to the eighth box.

Step 3: Please fill in your name and address below. This is where we will mail your magazines.

Please print clearly:





First Name: _____ Last Name: _____

Street Address: _____

City: _____ State: _____ Postal Code: _____ Country: _____

1-year print subscription to *Ceramics Monthly* | Rates are based on your location.
USA: US\$41.99 | Canada: US\$65.00 | Rest of World: US\$76.00
Tax: Ohio residents add 7.5% sales tax; Canadian residents add 5.0% GST

Step 4: Send this form to us by mail or fax.

<p>If paying by check, please mail your check in US dollars to the address below:</p> <p>The Ceramic Arts Network L-4163 Columbus, OH 43260-4163 USA</p>	<p>If paying by credit card, please complete the section below and mail or fax us this completed form.</p> <p>We accept the following credit cards:    </p> <p>Name On Card: _____</p> <p>Credit Card Number: _____</p> <p>Expires (MM/YY): _____ 3-Digit CVV Code: _____</p> <p>Authorized Signature: _____</p>
--	--

Paying by Credit Card? You can mail this form to us at the address above. Or simply fax it to: **+1-614-899-6109** (secure fax). For security purposes, DO NOT email us your credit card information.

Questions? Please email us at: customerservice@ceramicartsnetwork.org

Thank you for your support of *Ceramics Monthly* magazine!

Please cut along the line to remove this form.



Stay connected to the world of ceramics in the studio and beyond!

- Expert Techniques
- Studio Visits
- Artist Profiles and Interviews
- Recipes in Every Issue
- Helpful Studio Tips
- Inspiring Images
- Science for Potters

Have more fun making pottery!

- Start-to-Finish Projects for All Skill Levels
- Easy to Follow Step-by-Step Images
- Tips for the Studio, the Glaze room, and Your Toolbox
- Loads of Surface Decorating Ideas and Firing Tips



SUBSCRIBE TODAY!

To find out more, visit
ceramicsmonthly.org

To find out more, visit
potterymaking.org

buyers guide geographic locator

Quickly locating one of over 230 ceramic businesses is easy with this chart. You'll be able to find suppliers nearby and see what products and services they offer. Companies are arranged by country, state, then city. Need more contact information? See the alphabetical listings starting on page 62. If you don't see your local supplier, have them contact us to get into next year's listing.

	Prepared Clays	Prepared Glazes	Raw Materials	Kiln and Accessories	Wheels	Studio Equipment	Tools and Supplies	Books and Videos	Tile and Bisque	Services	Website
Alabama											
Benzle Porcelain (Huntsville)											• www.benzleporcelain.com
Arizona											
Dolan Tools (Phoenix)						•					www.ceramictools.com
Marjon Ceramics Inc. (Phoenix)	•	•	•	•	•	•	•	•	•	•	www.marjonceramics.com
Marjon Ceramics Inc. (Tucson)	•	•	•	•	•	•	•	•	•	•	www.marjonceramics.com
California											
Clay Factory Inc. (Apple Valley)						•					clayfactoryinc.myshopify.com
Phoenix Ceramic & Fire Supply (Arcata)	•	•	•	•	•	•	•	•	•	•	phoenixceramic.shop
Kemper Tools (Chino)						•					kempertools.com
Justin's Makery (Clovis)						•					www.justinsmakery.com
Laguna Clay Company (City of Industry)	•	•	•	•	•	•	•	•	•	•	www.lagunaclay.com
Jiffy Mixer Co. Inc. (Corona)						•					www.jiffymixer.com
Clay Mix (Fresno)	•	•	•	•	•	•	•			•	www.clay-mix.com
B & W Tile Co. Inc. (Gardena)									•		www.bwtile.com
Geil Kilns (Huntington Beach)				•	•						www.kilns.com
Art Decal Enterprises (Long Beach)								•	•		www.artdecalenterprises.com
Echo Ceramics (Los Angeles)	•	•	•	•	•	•		•	•		www.echoceramics.com
Olsen Kiln Kits (Mountain Center)				•				•			www.olsenkilns.com
Freeform Clay & Supply (National City)	•	•	•	•	•	•	•	•	•	•	www.freeformclay.com
American Museum of Ceramic Art (Pomona)								•			www.amoca.org
ClayPeople (Richmond)	•	•	•	•	•	•	•	•	•	•	www.claypeople.net
Industrial Minerals Co. (Sacramento)	•	•	•	•	•	•	•	•	•	•	www.clayimco.com
Alpha Fired Arts (Sacramento)	•	•	•	•	•	•	•	•	•	•	www.alpha-firedarts.com
HyperGlaze/Richard Burkett (San Diego)										•	www.hyperglaze.com
The Chinese Clay Art, USA (San Jose)	•	•				•	•	•			www.chineseclayart.com
Aardvark Clay & Supplies (Santa Ana)	•	•	•	•	•	•	•	•	•		www.aardvarkclay.com
Clay Planet (Santa Clara)	•	•	•	•	•	•	•	•	•	•	www.clay-planet.com
Pottery Texture Queen (Santa Rosa)						•					potterytexturequeen.com
Glaze Queen (Santa Rosa)		•									www.glazequeen.com
www.CeramicArtSpace.com (Sherman Oaks)	•	•	•	•	•	•	•	•	•	•	www.ceramicartspace.com
Sequoia Pottery (SlickFoot) (Springville)						•					www.sequoiapottery.com
Peter Puggger Mfg., Inc. (Ukiah)				•	•	•					peterpuggger.com
Pure & Simple Pottery Products (Willits)						•					pureandsimplepottery.com
Colorado											
Stone Leaf Pottery (Arvada)	•	•	•	•	•	•	•	•	•	•	www.stoneleafpottery.com
National Council on Education for the Ceramic Arts (Boulder)								•			www.nceca.net
Plinth Gallery (Denver)				•							www.plinthgallery.com
J.T. McMaster & Son (Denver)											j-t-mcmaster.myshopify.com
Continental Clay Co. (Denver)	•	•	•	•	•	•	•	•	•	•	www.continentalclay.com
Bluebird Manufacturing, Inc. (Ft. Collins)				•	•						www.bluebird-mfg.com
Enduring Images (Golden)					•						www.ceramicprinting.com
Glyptic Modeling Tools (Loveland)						•					www.glyptic.com
Anderson Ranch Arts Center (Snowmass Village)						•	•				www.andersonranch.org
Connecticut											
Rusty Kiln Ceramic Studio (North Windham)	•	•	•	•	•	•	•				www.rustykiln.com
R.T. Vanderbilt Co. Inc. (Norwalk)			•								www.rtvanderbilt.com

	Prepared Clays	Prepared Glazes	Raw Materials	Kiln and Accessories	Wheels	Studio Equipment	Tools and Supplies	Books and Videos	Tile and Bisque Services	Website
Delaware										
Nabertherm, Inc. (New Castle)			•							www.nabertherm.com
Florida										
Atlantic Pottery Supply Inc. (Atlantic Beach)	•	•	•	•	•	•	•	•		www.atlanticpotterysupply.com
Highwater Clays of Florida (Clearwater)	•	•	•	•	•	•	•	•		www.highwaterclays.com
Collet Clays Corp. (Coral Gables)	•									www.sio-2.com
Trinity Endeavors International (Lake Placid)						•			•	www.trinitydecals.com; www.tilesbyfran.com
Jen-Ken Kilns (Lakeland)				•						www.jenkenkilns.com
Laguna Clay Co./Axner.com (Oviedo)	•	•	•	•	•	•			•	www.axner.com
Florida Clay Art Co. (Sanford)	•	•	•	•	•	•			•	www.flclay.com
Morean Center for Clay (St. Petersburg)	•								•	www.moreanartscenter.org
Georgia										
Davens Ceramic Center (Atlanta)	•	•	•	•	•	•	•	•		www.davensceramiccenter.com
Olympic Kilns (Flowery Branch)				•	•					www.olympickilns.com
Larkin Refractory Solutions (Lithonia)				•					•	www.larkinrefractory.com
Idaho										
The Potter's Center (Garden City)	•	•	•	•	•	•	•			thepotterscenter.com
Wendt Pottery (Lewiston)	•	•	•	•	•	•			•	www.wendtpottery.com
Illinois										
Paasche Airbrush Co. (Chicago)							•			www.paascheairbrush.com
Sapir Studios (Chicago)							•			
Ceramic Supply Chicago (Elk Grove Village)	•	•	•	•	•	•				www.ceramicsupplychicago.com
Badger Air Brush Co. (Franklin Park)							•	•		www.badgerairbrush.com
Blick Art Materials (Galesburg)	•	•	•	•	•	•	•	•		www.dickblick.com
Nidec-Shimpo Ceramics (Glendale Heights)					•	•			•	www.shimpoceramics.com
Art Clay World, USA (Oak Lawn)	•	•		•		•	•	•	•	www.artclayworld.com
Midwest Ceramics LLC (Plano)	•	•					•		•	www.midwestceramics.com
U.S. Pigment Corp. (S. Elgin)	•	•	•	•					•	www.uspigment.com
Indiana										
United Art & Education (Ft. Wayne)	•	•		•	•	•	•	•		www.unitednow.com
AMACO & Brent (Indianapolis)	•	•		•	•	•				www.amaco.com
Brickyard Ceramics & Crafts (Indianapolis)	•	•	•	•	•	•	•	•		www.brickyardceramics.com
Royal & Langnickel Brush Mfg. (Munster)							•			art.royalbrush.com
Iowa										
Johnson Gas Appliance Co. (Cedar Rapids)				•	•					www.johnsongas.com
Bartlett Instrument Co. (Ft. Madison)				•						www.bartinst.com
Kansas										
Creative Paradise (Goddard)							•			www.creativeparadiseceramics.com
Bracker's Good Earth Clays (Lawrence)	•	•	•	•	•	•	•	•	•	www.brackers.com
Soldner Clay Mixers (Newton)						•				www.soldnerequipment.com
Evans Ceramic Supply (Wichita)	•	•	•	•	•	•		•	•	www.evansceramics.com
Starlite Mold Company (Wichita)									•	evansceramics.com/starlite-molds
Kentucky										
WiziWig Tools (Crestwood)							•			www.wiziwigtools.com
Kentucky Mudworks (Lexington)	•	•	•	•	•	•	•		•	kymudworks.com
Old Hickory Clay Co. (Mayfield)	•	•								www.oldhickoryclay.com
Louisiana										
Southern Pottery (Baton Rouge)	•	•	•	•	•	•	•			store100723761.company.site
Sinistra Studio LLC (Metairie)	•	•					•			www.sinistrastudio.com
Maine										
Portland Pottery Supply (Portland)	•	•	•	•	•	•	•	•	•	www.portlandpottery.com
Maryland										
Clayworks Supplies, Inc. (Baltimore)	•	•	•	•	•	•	•		•	www.clayworkssupplies.com
Elan Transfers (Frederick)							•			www.elantransfers.com
Chesapeake Ceramics Supply (Halethorpe)	•	•	•	•	•	•		•		chesapeakeceramics.com
Massachusetts										
Portland Pottery Supply South (Braintree)	•	•	•	•	•	•	•	•		www.portlandpottery.com
AccuAngle (Groveland)							•			www.accuangle.com
Amherst Potters Supply (Hadley)	•	•	•	•	•	•				www.amherstpotters.com

	Prepared Clays	Prepared Glazes	Raw Materials	Kiln and Accessories	Wheels	Studio Equipment	Tools and Supplies	Books and Videos	Tile and Bisque Services	Website
Massachusetts (continued)										
Gare Inc. (Harverhill)	•		•		•	•	•	•	•	store.gareceramics.com
Boston Kiln Sales & Service (Medford)			•	•	•					www.bostonkiln.com
KilnShield (Medford)			•							www.kilnshield.com
The Potters Shop and School (Needham)						•	•			www.thepottersshopandschool.com
Pinch (Northampton)										www.pinchgoods.com
Sheffield Pottery Inc. (Sheffield)	•	•	•	•	•	•	•	•	•	www.sheffield-pottery.com
Ceramics Consulting Services (Southampton)							•			www.jeffzamek.com
Saint-Gobain Ceramic Materials (Worcester)			•							www.ceramicsrefractories.saint-gobain.com
Michigan										
Rovin Ceramics (Ann Arbor)	•	•	•	•	•	•			•	www.rovinceramics.com
Pebble Press, Inc. (Ann Arbor)							•	•		www.piepenburgstudios.com
Evenheat Kiln Inc. (Caseville)			•							www.evenheat-kiln.com
Runyan Pottery Supply Inc. (Clio)	•	•	•	•	•	•	•	•	•	www.runyanpotterysupply.com
GR Pottery Forms (Grand Rapids)						•				www.grpotteryforms.com
Minnesota										
Master Kiln Builders (Farmington)			•						•	www.kilnbuilders.com
Continental Clay Co. (Minneapolis)	•	•	•	•	•	•	•	•	•	www.continentalclay.com
Smith-Sharpe Fire Brick Supply (Minneapolis)			•						•	www.kilnshelf.com
Minnesota Clay Co. (Plymouth)	•	•	•	•	•	•	•	•	•	www.mnclay.com
Mississippi										
Dogwood Ceramic Supply (Gulfport)	•	•	•	•	•	•	•	•	•	www.dogwoodceramics.com
Mississippi School of Folk Arts (Natchez)	•	•	•	•	•	•	•	•	•	www.msfolkart.org
Missouri										
Mike Cerv Pots (Kansas City)	•	•	•	•	•	•		•	•	mikecervpots.myshopify.com
ClayStamps (Kansas City)							•		•	www.claystamps.com
Krueger Pottery Supply (St. Louis)	•	•	•	•	•	•	•	•	•	www.kruegerpottery.com
SilkPaint (Waldron)							•		•	www.silkpaint.com
Montana										
Archie Bray Foundation (Helena)	•	•	•	•	•	•	•		•	www.archiebrayclay.com
Sunshine Cobb (Helena)							•	•		www.sunshinecobb.com
Flecks and Specks (Missoula)			•				•			www.flecksandspecks.com
Nebraska										
Glaser Ceramics (Lincoln)					•	•				www.glaserceramics.com
Nevada										
Cress Mfg. Co. (Carson City)			•							www.cressmfg.com
Aim Kiln Mfg. (Minden)	•		•			•			•	aimkiln.com
New Jersey										
Creative Hobbies, Inc. (Bellmawr)		•	•			•		•		ehobbycraft.com
Peters Valley School of Craft (Layton)									•	www.petersvalley.org
Ceramic Supply Inc. (Lodi)	•	•	•	•	•	•	•	•	•	ceramic-supply-inc.myshopify.com
L&L Kiln Mfg. Inc. (Swedesboro)			•		•					hotkilns.com
Hammill & Gillespie Inc. (Union)			•							www.hamgil.com
New Mexico										
Coyote Clay & Color (Albuquerque)		•								www.coyoteclay.com
Free Freight Pottery Supply LLC (Albuquerque)	•	•	•	•	•	•				www.freefreightpotterysupply.com
New Mexico Clay, Inc. (Albuquerque)	•	•	•	•	•	•	•	•	•	www.nmclay.com
New York										
Studio Sales and Schoolhouse #3 Pottery (Avon)			•		•	•			•	www.studiosalespottery.com
Vent-A-Kiln Corp. (Buffalo)			•		•					ventakiln.com
Ceramic Arts Library (Corning)							•		•	www.ceramicartslibrary.com
PCF Studios (Honeoye)						•	•		•	philippefaraut.com
Bailey Pottery Equipment (Kingston)	•	•	•	•	•	•	•	•	•	www.baileypottery.com
Peekskill Clay Studios, The Hat Factory (Peekskill)	•								•	www.peekskillclaystudios.com
Clayscapes Pottery Inc. (Syracuse)	•	•	•	•	•	•				www.clayscapespottery.com
Oneida Air Systems, Inc. (Syracuse)						•				www.oneida-air.com/ceramic
Laguna Clay Company (Syracuse)	•	•	•	•						www.lagunaclay.com
Alpine Kilns and Equipment LLC (Warwick)			•	•	•	•			•	alpinekilns.com
Doo-Woo Tools LLC (Warwick)						•				
Rochester Ceramics, Inc. (Webster)	•	•	•	•	•	•	•	•		www.rochesterceramics.com

	Prepared Clays	Prepared Glazes	Raw Materials	Kiln and Accessories	Wheels	Studio Equipment	Tools and Supplies	Books and Videos	Tile and Bisque Services	Website
North Carolina										
Highwater Clays, Inc. (Asheville)	•	•	•	•	•	•	•	•	•	www.highwaterclays.com
Mudtools (Bat Cave)							•			www.mudtools.com
Carolina Clay Connection (Charlotte)	•	•	•	•	•	•	•	•	•	www.carolinaclay.com
Claymakers (Durham)	•	•	•			•			•	www.claymakers.org
Resco Products Inc. (Greensboro)			•							www.rescoproducts.com
Original Hi Roller (Pottery Carolina, LLC) (Hickory)					•					www.originalhiroller.com
STARworks Ceramics Materials & Research (Star)	•	•	•	•	•	•	•		•	www.starworksnc.org
Williams Supply (Star)	•	•	•	•	•	•				www.williamsupplync.com
Fat Cat Pottery Inc. (Wilmington)	•	•	•	•	•	•			•	www.fatcatpottery.com
Ohio										
National Artcraft Co. (Aurora)	•			•	•	•			•	www.nationalartcraft.com
Laguna Clay Co. (Byesville)	•	•	•	•	•	•	•	•	•	www.lagunaclay.com
Vulcan Kilns (Centerville)				•	•				•	www.vulcankilns.com
Queen City Clay (Cincinnati)	•	•	•	•	•	•	•		•	www.queencityclay.com
Cowan's (Cincinnati)									•	cowans.hindmanauctions.com
Aegean Sponge Co. (Cleveland)						•				www.aegeansponge.com
RAM Products Inc. (Columbus)					•					www.ramprocess.com
Columbus Clay (Columbus)	•	•	•	•	•	•	•	•	•	www.columbusclay.com
Cornell Studio Supply (Dayton)	•	•	•	•	•	•	•	•	•	www.cornellstudiosupply.com
Innovative Ceramic Corp. (East Liverpool)						•			•	www.innovativeceramic.com
Mason Color Works Inc. (East Liverpool)			•							www.masoncolor.com
Krumor Inc. (Valley View)				•						www.krumor.com
Orton Ceramic Foundation (Westerville)					•		•		•	www.ortonceramic.com
Olympia Enterprises Inc. (Youngstown)		•				•		•		www.olympiadecals.com
Oregon										
Georgies Ceramic and Clay Co. (Eugene)	•	•	•	•	•	•	•	•	•	www.georgies.com
Georgies Ceramic & Clay Co. Inc. (Portland)	•	•	•	•	•	•	•	•	•	www.georgies.com
Mudshark Studios (Portland)									•	mudsharkstudios.com
Ritual Glaze. (Portland)		•								www.ritualglaze.com
Skutt Ceramic Products (Portland)				•	•	•				www.skutt.com
Wizard Glaze (Portland)		•								www.wizardglaze.com
Pennsylvania										
L&L Kiln Mfg. Inc. (Boothwyn)				•						hotkilns.com
Insulating Firebrick, Inc. (Claysburg)				•						www.insulatingfirebrick.com
The Ceramic Shop (Norristown)	•	•	•	•	•	•	•	•	•	www.theceramicshop.com
The Clay Studio (Philadelphia)									•	www.theclaystudio.org
Ceramic Supply Pittsburgh (Pittsburgh)	•	•	•	•	•	•				www.ceramicsupplypittsburgh.com
Standard Ceramic Supply Co. (Pittsburgh)	•	•	•	•	•	•				www.standardceramic.com
Petro Mold Company (Waterford)									•	www.petro molds.com
South Carolina										
Newberry Arts Center (Newberry)									•	www.newberryartscenter.com
Clay-King.com (Spartanburg)	•	•		•	•	•			•	www.clay-king.com
South Dakota										
Dakota Potters Supply (Sioux Falls)	•	•	•	•	•	•	•		•	www.dakotapotters.com
Tennessee										
Ward Burner Systems (Dandridge)				•	•		•		•	www.wardburner.com
Arrowmont School of Arts & Crafts (Gatlinburg)						•	•		•	www.arrowmont.org
Mighty Mud (Knoxville)	•	•	•	•	•	•			•	www.mightymud.com
Mid-South Ceramic Supply Co. (Nashville)	•	•	•	•	•	•	•	•	•	www.midsouthceramics.com
Clay Lady's Campus Studios (Nashville)	•	•	•	•	•	•	•		•	theclaylady.com
Texas										
Armadillo Clay & Supplies (Austin)	•	•	•	•	•	•	•	•	•	www.armadilloclay.com
Trinity Ceramic Supply Inc. (Dallas)	•	•	•	•	•	•	•			www.trinityceramic.com
American Ceramic Supply Co. (Ft. Worth)	•	•		•	•	•	•	•	•	www.AmericanCeramics.com
Dry Creek Pottery (Granbury)									•	www.drycreekpottery.com
Texas Pottery Supply & Clay Co. (Halton City)	•	•	•	•	•	•	•	•	•	www.texaspottery.com
Ceramic Store of Houston, LLC (Houston)	•	•	•	•	•	•	•	•	•	store.ceramicstoreinc.com
Paragon Industries, L.P. (Mesquite)				•						www.paragonweb.com

	Prepared Clays	Prepared Glazes	Raw Materials	Kiln and Accessories	Wheels	Studio Equipment	Tools and Supplies	Books and Videos	Tile and Bisque	Services	Website
Texas (continued)											
Old Farmhouse Pottery (Rusk)								•			www.farmpots.com
San Angelo Museum of Fine Arts (San Angelo)										•	www.samfa.org
Utah											
Capital Ceramics Inc. (Salt Lake City)	•	•	•	•	•	•				•	www.artisticindustriesutah.com
Vermont											
StudioPro (Whitingham)						•	•				www.studioprobats.com
Virginia											
Clayworks Supplies, Inc. (Alexandria)	•	•	•	•	•	•	•	•	•	•	www.clayworkssupplies.com
The Art League (Alexandria)							•				www.theartleague.org
The Kiln Doctor Inc. (Front Royal)	•	•	•	•	•	•	•	•	•	•	www.thekilndoctor.com
Tin Barn Pottery Supplies at Manassas Clay (Manassas)	•	•	•	•	•	•	•	•	•	•	www.manassasclay.com
Clayworks Supplies, Inc. (Richmond)	•	•	•	•	•	•	•	•	•	•	www.clayworkssupplies.com
Washington											
North Star Equipment Inc. (Cheney)						•	•				www.northstarequipment.com
Giffin Tec Inc. (Lummi Island)						•	•				www.giffingrip.com
Crucible Kilns (Seattle)	•	•	•	•	•	•	•	•	•	•	www.seattlepotterysupply.com
New Century Ceramic Arts Inc. (Seattle)	•							•			www.paperclayart.com
Seattle Pottery Supply (Seattle)	•	•	•	•	•	•	•	•	•	•	www.seattlepotterysupply.com
Rings & Things Wholesale (Spokane)								•			www.rings-things.com
Clay Art Center (Tacoma)	•	•	•	•	•	•	•	•	•	•	www.clayartcenter.net
West Virginia											
Jen Allen Ceramics (Morgantown)								•			www.jenniferallceramics.com
Shalya Marsh (Morgantown)								•			shalyamarshstudios.com
Danser, Inc. (Parkersburg)				•							www.danserinc.com
Wisconsin											
MKM Pottery Tools LLC (Appleton)								•			www.mkmpotterytools.com
Nasco Arts & Crafts (Fort Atkinson)	•	•	•	•	•	•	•				www.enasco.com
School Specialty/ Sax Arts & Crafts (Greenville)	•	•		•	•	•	•	•	•		store.schoolspecialty.com
Paasche Airbrush Co. (Kenosha)								•			www.paascheairbrush.com
Aves Studio (River Falls)								•			www.avesstudio.com
The Potter's Shop (Waukesha)	•	•	•	•	•	•	•				www.pottersshop.com
Socwell LLC (Whitewater)						•	•				www.4clay.com
Australia											
Clay Sydney Tools (Enmore)								•			www.claysydneytools.com
Canada											
Ceramic Arts & Crafts Supply (Burlington)	•	•		•	•	•	•	•	•	•	www.ceramicarts.com
Spectrum Glazes (Concord)		•	•	•			•	•			www.spectrumglazes.com
Sial (Laval)	•	•	•	•	•	•	•	•	•	•	www.sial-canada.com
PotteryVideos.com (Gabriola)								•			www.potteryvideos.com
Digitalfire Corp. (Medicine Hat)								•			insight-live.com
Plainsman Clay Ltd. (Medicine Hat)	•	•	•	•	•	•	•	•	•	•	plainsmanclays.com
Medalta in the Historic Clay District (Medicine Hat)											www.medalta.org
Euclid's Elements/The Pottery Supply House (Oakville)	•	•	•	•	•	•	•	•	•	•	www.euclids.com
Brennan Pottery (Ottawa)								•			www.kaitlynbrennan.com
Cone Art Kilns Inc. (Richmond Hill)				•							coneartkilnsshop.com
Tucker's Pottery Supplies Inc. (Richmond Hill)	•	•	•	•	•	•	•	•	•	•	tuckerspotteryeshop.com
Bamboo Tools (Surrey)								•			www.bambootools.com
Greenbarn Potters Supply Ltd. (Surrey)	•	•	•	•	•	•	•	•	•		greenbarn.com
France											
A.I.R. Vallauris, Galerie Aqui Siam Ben (Vallauris)								•		•	www.air-vallauris.org
Italy											
La Meridiana International Ceramics School (Certaldo)										•	www.lameridiana.fi.it
The Netherlands											
Blaauw Kilns (1046 BE, Amsterdam)				•	•	•					www.blaauwproducts.com
United Kingdom											
Bailey Decal Ltd. (Stoke-on-Trent)								•		•	baileydecal.co.uk
Glost Glazes	•										www.glost-glaze.com

buyers guide

company directory listing



AARDVARK CLAY & SUPPLIES

1400 E. Pomona St.
Santa Ana, CA 92705-4812
714-541-4157

Website: aardvarkclay.com

Complete line of materials and equipment for potters, artists, hobbyists, and production facilities.

AEGEAN SPONGE CO.
11029 Briggs Rd.
Cleveland, OH 44111
216-749-1927 Toll-Free: 800-276-8542
Website: www.aegeansponge.com

Importer of natural and synthetic sponges: silk, elephant ear, sea, and wool. Wholesaler of ceramic and craft supplies.

AIM KILN MFG.
2516 Business Pkwy., Unit E
Minden, NV 89423
775-267-2607 Toll-Free: 800-246-5456
Website: aimkiln.com

Electric and gas-fired kilns, kiln controls, and kiln accessories. Custom builds and repairs.

A.I.R. VALLAURIS, GALERIE AQUI SIAM BEN
Place Lisnard, 1 Boulevard des Deux Vallons
Vallauris, Provence-Alpes-Côte d'Azur 06220, France
+33 493-64-65-50
Website: www.GalerieAquiSiamBen.org;
www.air-vallauris.org

A.I.R. Vallauris welcomes resident artists from around the world to its lodgings, studios, and gallery.



ALLIGATOR CLAY/SOUTHERN POTTERY

2721 W. Perdue Ave.
Baton Rouge, LA 70814
225-932-9457

Website: store100723761.company.site

A division of Southern Pottery Equipment & Supplies LLC. Providing clays, materials, and tools to ceramic artists. Manufacturing a range of moist clays including custom clay bodies.

ALPHA FIRED ARTS
4675 Aldona Ln.
Sacramento, CA 95841
916-484-4424 Toll-Free: 800-655-3611
Website: www.alpha-firedarts.com
Largest selection of ceramic supplies in Northern California.

ALPINE KILNS AND EQUIPMENT LLC
PO Box 1275
Warwick, NY 10990-1275
845-987-9589 Toll-Free: 888-222-9196
Website: www.alpinekilns.com

Manufacturer of front-loading gas and electric kilns; tables for glaze formulating, working, and wedging; and spray booths. Offering other brands of pottery wheels, pugmills, and kilns.



AMACO/BRENT

6060 Guion Rd.
Indianapolis, IN 46254-1222
317-244-6871 Toll-Free: 800-374-1600
Website: www.amaco.com

Easy-to-use products, how-to videos, and technical support.

AMERICAN CERAMIC SUPPLY CO.
2442 Ludelle St.
Ft. Worth, TX 76105-1060
866-535-2651
Website: www.AmericanCeramics.com

Retail and wholesale ceramic equipment and supplies—kilns, wheels, glazes, brushes, clay, tools, bisque, and more. Customized/personalized packages. Education and training. Serving potters, artists, educators, hobbyists, traditional, and PYOP studios. Certified master distributor for major brands.

AMERICAN MUSEUM OF CERAMIC ART
399 N Garey Ave.
Pomona, CA 91767
909-865-3146
Website: www.amoca.org

Offering studio membership, as well as adult and children's ceramics classes.

AMHERST POTTERS SUPPLY
47 East St. #3
Hadley, MA 01035
413-586-4507
Website: www.amherstpotters.com

Specialize in custom-mixed, de-aired clays and an assortment of our own cone-6 glazes.

ANDERSON RANCH ARTS CENTER
PO Box 5598
Snowmass Village, CO 81615
970-923-3181
Website: www.andersonranch.org

ARCHIE BRAY FOUNDATION
2915 Country Club Ave.
Helena, MT 59602-9240
406-443-3502
Website: archiebrayclay.com
Manufacturer of moist clay—19 stock bodies with custom-blend capabilities. US distributor of Alberta and Ravenscrag slips. Supplier of Bray-Poxy, a moldable epoxy for post-firing repairs, and Bray Patch, a repair material for use on greenware or bisqueware.

ARMADILLO CLAY & SUPPLIES
3307 E. Fourth St.
Austin, TX 78702
512-385-7311
Website: www.armadilloclay.com
One-stop shop giving you a chance to see and touch the products. Sell both retail and wholesale.

ARROWMONT school of arts and crafts

ARROWMONT SCHOOL OF ARTS & CRAFTS
556 Parkway
Gatlinburg, TN 37738
865-436-5860
Website: www.arrowmont.org

Center for contemporary arts and crafts education. Offering weekend, one-week and two-week workshops. Artists-in-residence, studio assistantships, work-study, and scholarship opportunities are available.

THE ART LEAGUE
105 North Union St.
Alexandria, VA 22314
703-683-2323
Website: www.theartleague.org
Offers classes and workshops for every skill level, from ages five and up, in fine arts and many fine crafts.

ART CLAY WORLD, USA
4535 Southwest Hwy.
Oak Lawn, IL 60453
708-857-8800 Toll-Free: 866-381-0100
Website: www.artclayworld.com
Offering supplies, materials, and classes in various media including multiple styles of clays.

ART DECAL ENTERPRISES
607 W. Whittier Blvd.
Montebello, CA 90640
562-434-2711
Website: www.artdecalenterprises.com
Offering single and multi-color, made-to-order water-slide onglaze, inglaze, and glass decals.

ATLANTIC POTTERY SUPPLY INC.
1904 Debarry Ave.
Orange Park, FL 32073
904-249-4499
Website: www.atlanticpotterysupply.com
Retail and wholesale pottery supply business.

AVES STUDIO
PO Box 344
River Falls, WI 54022
715-386-9097 Toll-Free: 800-261-2837
Website: www.avesstudio.com
Manufactures self-hardening sculpting clays, machés, and repair compounds that are safe, user friendly, non-shrinking, noncracking, and waterproof.

LAGUNA CLAY CO./AXNER.COM
490 Kane Ct.
Oviedo, FL 32765
407-365-2600 Toll-Free: 800-843-7057
Website: www.axner.com
Laguna, Miller, and Axner clays, Axner colored porcelains and paper clays, Laguna dry and liquid glazes, Axner and Pacifica potters wheels, Axner and Laguna ware carts, Laguna spray booths, Axner glaze and work tables, pugmills, clay mixers, slab rollers, stains, raw materials, bats, tools, banding wheels, and cones.

B & W TILE CO. INC.
12517 Sherman Way
North Hollywood, CA 91605
310-538-9579 Toll-Free: 800-499-TILE
Website: www.bwtile.com
Manufacturing tile and tile trim. Make and sell dry-pressed ceramic body tiles in a variety of sizes and a full line of trim. Sell both retail and wholesale.

BADGER AIR BRUSH CO.
2740 Washington Blvd. Unit C.
Bellwood, IL 60104
847-678-3104 Toll-Free: 800-AIR-BRUSH
Website: www.badgerairbrush.com
Manufacturing US-made Badger and Thayer & Chandler airbrushes and accessories for a vast array of spray needs.

BAILEY DECAL LTD.
Trent House, Dunning St.
Stoke-on-Trent, ST6 5AP, United Kingdom
44(0)1782-524400
Website: baileydecal.co.uk



Bailey Pottery Equipment

BAILEY POTTERY EQUIPMENT
PO Box 1577
Kingston, NY 12402
845-339-3721, Toll-Free: 800-431-6067
Website: www.baileypottery.com
Offering clay, tools, glazes, and major equipment.

BAMBOO TOOLS
PO Box 74009
Surrey, BC V4N 5H9, Canada
Website: bambootools.com
Offering lightweight, durable bamboo pottery tools.

BARTLETT INSTRUMENT CO.
1032 Ave. H
Ft. Madison, IA 52627
319-372-8366
Website: www.bartlettinstrument.com
Design and produce controllers used by kiln manufacturers. Many types, including a touchscreen model that integrates with a free mobile app.

BENZLE PORCELAIN
706 Randolph Ave.
Huntsville, AL 35801
256-653-3654
Website: www.benzleporcelain.com
For information visit the La Meridiana website or email curtisbenzle@gmail.com.

BLAAUW KILNS
Bornhout 8
1046 BE, Amsterdam, The Netherlands
0031-20-482-4696
Website: www.blaauwproducts.com
Consulting, design, and production of gas and electric kilns.

BLICK®

BLICK ART MATERIALS
695 U.S. Hwy. 150 E.
Galesburg, IL 61402-1267
309-343-6181 Toll-Free: 800-447-8192
Website: www.dickblick.com
Offering clays, glazes, kilns, tools, wheels, and accessories. Distributor for Amaco, Skutt, Laguna, Shimpo, Kemper, Bailey, and more.

BLUEBIRD MANUFACTURING, INC.
PO Box 2307
Ft. Collins, CO 80522-2307
970-484-3243
Website: www.bluebirdclay.com
Manufacture pugmills (3 sizes), with cast-aluminum barrels and stainless-steel parts. Manufacture clay mixers (2 sizes) with stainless-steel buckets. Manufacture Soldner Wheels: P Series, and S Series.

BOSTON KILN SALES & SERVICE
33 Frederick Ave.
Medford, MA 02155
617-926-1802
Website: bostonkiln.com
Provide sales, custom installation, and repairs for kilns and wheels, and consulting to schools and colleges regarding technical and code issues. Provides solutions for kiln venting and exhaust, air-quality issues.

BRACKER'S GOOD EARTH CLAYS
1831 E. 1450 Rd.
Lawrence, KS 66044
888-822-1982
Website: www.brackers.com

Supplies ceramic and sculptural materials as well as equipment, tools, and accessories. We also offer kiln and wheel repair services and ceramics advice consultations.

BRENNAN POTTERY
Ottawa, ON, Canada
Website: www.kaitlynbrennan.com
The Pottery Clamp is a 3D-printed pottery decorating tool developed for use in a ceramic studio practice. Improves studio ergonomics and makes it easier to make and decorate cylinders and mugs. The tool is designed much like the chuck in your power drill - depending on which way to turn it the jaws either get closer together or further apart holding your work in place.

BRICKYARD CERAMICS & CRAFTS
6060 Guion Rd.
Indianapolis, IN 46254
317-244-5230 Toll-Free: 800-677-3289
Website: www.brickyardceramics.com
Supplier of clay, kilns, slip, glazes, tools, molds, bisque, wheels, and slab rollers plus art and craft products. Brands include Amaco, Brent, Duncan, Excel, & Mayco.

CAPITAL CERAMICS INC.
2601 S Constitution Blvd. Ste. #100
Salt Lake City, UT 84118
801-466-6471
Website: www.artisticindustriesutah.com
Pottery supplies and equipment for Utah and the surrounding area.



Carolina Clay Connection

CAROLINA CLAY CONNECTION
208 N. Polk St.
Pineville, NC 28134
704-376-7221
Website: carolinaclay.com
Supplier, featuring Standard, Highwater, and Laguna clays. Carry equipment by most major manufacturers.

CERAMIC ARTS & CRAFTS SUPPLY
3103 Mainway Dr.
Burlington, ON L7M 1A1, Canada
905-335-1515 Toll-Free: 800-265-3232
Website: www.ceramicarts.com
Servicing potters and ceramic painting studios. Offering kilns, glazes, clay, bisque, brushes, tools, slip, molds, and more.

CERAMIC ARTS LIBRARY
79 E. Third St.
Corning, NY 14830-3101
607-962-6042
Website: www.ceramicartslibrary.com
We sell hard-to-find titles, used, and out-of-print books in the ceramic field.

WWW.CERAMICARTSPACE.COM
7101 Bryant Irvin Rd
P.O. Box 33094
Fort Worth, TX 76162
818-782-1500 Toll-Free: 888-CERAMIX
Website: www.ceramicartspace.com
Online supply store; bisque, plastercraft, glazes, tools, kiln supplies, acrylics, and much more.

THE CERAMIC SHOP
1200 Markley St.
Norristown, PA 19401
888-457-4236
Website: www.theceramicshop.com
Supplier online and in store. Manufacturer of the Hydro-Bat, Roselli Kiln Stilts, and other supplies.

CERAMIC STORE OF HOUSTON, LLC
5247 Langfield Rd.
Houston, TX 77040
713-864-6442 Toll-Free: 800-290-8990
Website: www.ceramicstoreinc.com
Serving the Houston metro area.

Ceramic supply

CERAMIC SUPPLY CHICAGO
2480 Delta Ln.
Elk Grove Village, IL 60007
847-425-1900
Website: ceramicsupplychicago.com
Standard wet clays; raw clay and glaze materials; plasters; equipment and tools.

CERAMIC SUPPLY INC.
7 Rt. 46 W.
Lodi, NJ 07644
973-340-3005, Toll-Free: 800-723-7264
Website: ceramic-supply-inc.myshopify.com
Standard wet clays; raw clay and glaze materials; plasters; equipment and tools.

CERAMIC SUPPLY PITTSBURGH
1 Walnut St.
Carnegie, PA 15106
412-489-5240
Website: ceramicsupplypittsburgh.com
Standard wet clays; raw clay and glaze materials; plasters; equipment and tools.

CERAMICS CONSULTING SERVICES
6 Glendale Woods Dr.
Southampton, MA 01073
413-527-7337
Website: www.jeffzamek.com
Technical information on clays, glazes, slip casting, raw materials, kilns, equipment, product development, ceramic toxicology, and causes/corrections for defects.

CHESAPEAKE CERAMICS SUPPLY
4710 Benson Ave.
Halethorpe, MD 21227-1411
410-247-1270 Toll-Free: 800-962-9655
Website: www.chesapeakeceramics.com
Carrying Amaco/Brent, Mayco, Duncan, Skutt, Paragon, Shimpo, and more. Technical support, and workshops.

美國中華陶藝中心 The Chinese Clay Art, USA

THE CHINESE CLAY ART, USA (ONLINE ONLY)
408-343-3919 Toll-Free: 800-689-2529
Website: www.chineseclayart.com
Web store, manufacturer, and wholesale. Offer clay tools, brushes, materials, glazes, and books.



CLAY ART CENTER
2636 Pioneer Way E.
Tacoma, WA 98404
253-922-5342 Toll-Free: 800-952-8030
Website: clayartcenter.net
Custom clay and glazes. Distributors for Skutt, Laguna, Kemper, Duncan, AMACO, and most other manufacturers. Offer kiln, wheel, and equipment repair.

CLAY FACTORY INC.
PO BOX 548
San Luis Rey, CA 92068
760-741-3242
Website: www.clayfactoryinc.com
Carrying Cernit Modeling Clay, Jacquard products, Kemper tools, Artistic wire, and Makin's clay and tools.

THE CLAY LADY'S CAMPUS STUDIOS, ARTIST CO-OP, GALLERIES & MID-SOUTH CERAMICS
1416 Lebanon Pike
Nashville, TN 37210
615-242-0346 Toll-Free: 866-203-5286
Website: www.theclaylady.com
The Clay Lady's Campus is 35,000 square feet of studios, artist co-op, galleries, and Mid-South Ceramic Supply.

CLAY MIX
1003 N. Abby St.
Fresno, CA 93701
559-485-0065

Website: www.clay-mix.com

Supplies and equipment: clay, glazes, tools, kilns, potter's wheels, slab rollers, raw materials, and kiln repairs. Offers studio space, classes, workshops, and exhibitions.

CLAY PLANET
1775 Russell Ave.
Santa Clara, CA 95054
408-295-3352 Toll-Free: 800-443-CLAY
Website: shop.clay-planet.com

Manufacturer of over 25 custom clays, and over 400 Western Glaze colors. Owner of Aftosa Brand ceramic products and accessories. Kiln and equipment repair, sales, and services. Visit our retail store or shop online.

THE CLAY STUDIO
1425 N. American St.
Philadelphia, PA 19122
215-925-3453 Ext.17
Website: www.theclaystudio.org

CLAY SYDNEY TOOLS
37-39 Stanmore Rd, Enmore NSW 2042, Australia
Website: www.claydneytools.com

Using HDPE (high-density polyurethane) plastic waste, we turn it into our pottery tools, giving the plastic a new life. Producing ergonomic ribs with a variety of edges and designs.

CLAY-KING.COM
125 Ben Abi Rd.
Spartanburg, SC 29307
864-579-1752 Toll-Free: 888-838-3625
Website: www.clay-king.com

Online discount store with a huge product index for all levels of ceramic artists and potters.

CLAYMAKERS
470 Salem St.
Durham, NC 27703
919-530-8355
Website: www.claymakers.org
Classes, retail clay, supplies and equipment, firing services, individual studio rentals, and gallery.

CLAYPEOPLE
623 S. 32nd St.
Richmond, CA 94804-2141
510-236-1492 Toll-Free: 888-236-1492
Website: claypeople.net
Ceramic supply, plaster, equipment sales, and service.

CLAYSCAPES POTTERY INC.
1003 W. Fayette St.
Syracuse, NY 13204
315-424-6868
Website: www.clayscapespottery.com
Offering a wide variety of clay bodies, wet and dry glazes, kilns, wheels, and tools.

CLAYSTAMPS
10407 Bales Ave.
Kansas City, MO 64137
816-565-4300
Website: www.claystamps.com
Custom engraved metal stamps for ceramic artists.

CLAYWORKS SUPPLIES, INC.
5704 General Washington Dr., Ste. C
Alexandria, VA 22312
703-256-7500
Website: www.clayworkssupplies.com
Supply store and delivery service supplying Maryland, DC, Southeast Pennsylvania, Delaware, Northern Virginia, and Richmond.

CLAYWORKS SUPPLIES, INC.
2277 Dabney Rd., Ste. F, Richmond, VA 23230
804-918-7722
Website: www.clayworkssupplies.com

CLAYWORKS SUPPLIES, INC.
4625 Falls Rd., Baltimore, MD 21209
410-235-5998
Website: www.clayworkssupplies.com



COLLET CLAYS CORP.
786-431-3393 (9am to 1pm EST)
Website: www.sio-2.com
Manufacturer of clay in Barcelona, Spain. Warehouse in Savannah, Georgia. Our clay ranges from white, red, and black earthenware to white, gray, and black stoneware and sculpture clay. Specialty clays include black, blue, and paper porcelain and 3D printing clays.

COLUMBUS CLAY
1080 Chambers Rd.
Columbus, OH 43212
614-488-9600 Toll-Free: 866-410-2529
Website: www.columbusclay.com
Supplying clays, materials, kilns, potter's wheels, tools, glazes, bisque, and more.

CONE ART KILNS INC.
15 W. Pearce St., Unit #7
Richmond Hill, ON L4B 1H6 Canada
905-889-7705 Toll-Free: 800-304-6185
Website: coneartkilnsshop.com
Manufacturing kilns with distribution in North America, South America, Europe, and the Middle East.



CONTINENTAL CLAY CO.
1101 Stinson Blvd.
Minneapolis, MN 55413
612-331-9332 Toll-Free: 800-432-2529
Website: www.continentalclay.com
Supplying clays; Amaco, Duncan, Mayco, and Spectrum glazes; materials; chemicals; kilns; pottery wheels; tools; books equipment. 25+ clay bodies and custom blending.

CONTINENTAL CLAY CO.
5303 E. 47th Ave., Unit N
Denver, CO 80216
303-355-9332 Toll-Free: 800-432-2529
Website: www.continentalclay.com

CORNELL STUDIO SUPPLY
8290 N. Dixie Dr.
Dayton, OH 45414
937-454-0357
Website: www.cornellstudiosupply.com
Offering workshops and classes. All your clay needs in the heart of the Miami Valley.

COWAN'S
6270 Este Ave.
Cincinnati, OH 45232
513-871-1670
Website: cowans.hindmanauctions.com
Semi-annual Modern and contemporary ceramics auctions.

COYOTE CLAY & COLOR
5107 Edith Blvd. NE
Albuquerque, NM 87107-5107
866-344-2250
Website: www.coyoteclay.com
Supplying glazes in pints, gallons, and three-gallon buckets, or packaged dry. Underglazes also available.

CREATIVE HOBBIES, INC.
900 Creek Rd.
Bellmawr, NJ 08031
856-933-2540 Toll-Free: 800-THE-KILN
Website: ehobbycraft.com
Wholesale prices to businesses. Freight allowances based on order size.

CREATIVE PARADISE
PO Box 734
Goddard, KS 67052
316-794-8621
Website: www.creativeparadiseglass.com
Ceramic design firm dedicated to offering unique hand-building forms and tools.



CRESS MFG. CO.
4736 Convair Dr.
Carson City, NV 89706
775-884-2777 Toll-Free: 800-423-4584
Website: www.cressmfg.com
Producing electric kilns from small test units to large production-grade equipment.

DAKOTA POTTERS SUPPLY
2315 W. Madison St.
Sioux Falls, SD 57104
605-332-1946
Website: www.dakotapotters.com
Manufacturing pugged clay and distributing glazes, kilns, and equipment for Paragon, Skutt, and L&L Kilns, Laguna, Coloramics/Mayco, Spectrum Glazes, Vent-A-Kiln, Peter Puggger, Amaco/Brent, and North Star.

DANSER, INC.
PO Box 4098
Parkersburg, WV 26104
304-679-3666
Website: danserinc.com
Steel and sheet metal fabricator specializing in custom fiber-lined gas kilns. Also manufacture and install ductwork and combustion systems.

DAVENS CERAMIC CENTER
5076 Peachtree Rd.
Atlanta, GA 30341
770-451-2105 Toll-Free: 800-695-4805
Website: www.davensceramiccenter.com
Complete line of pottery equipment and supplies.

DIGITALFIRE CORP.
125 - 2800 13th Ave.
Medicine Hat, AB T1A 3P9, Canada
Website: insight-live.com
Producer of Digitalfire Insight-Live.com. Use your online account to store, search, report, adjust, fix, formulate, and test glazes and clay bodies.

DOGWOOD CERAMIC SUPPLY
12590 Dedeaux Rd.
Gulfport, MS 39503
228-831-4848
Website: www.dogwoodceramics.com
Distributor of kilns, clay, glazes, wheels, molds, and related supplies.

DOLAN TOOLS
PO Box 45393
Phoenix, AZ 85064
602-466-1814 Toll-Free: 800-624-3127
Website: www.dolantools.com
Pottery tools all individually made of knife steel. Custom orders available. Dealers welcome.

DOO-WOO TOOLS LLC
PO Box 1275
Warwick, NY 10990-1275
845-987-9589
Wholesale pottery tools designed by Dong-Hun Chung of South Korea. A variety of tool sets, individual tools, and custom tool sets.

DRY CREEK POTTERY
8400 Cleburne Hwy.
Granbury, TX 76049
817-578-1563
Website: www.drycreekpottery.com
Offering teacher workshops and lesson plan books all relating to clay.

ECHO CERAMICS

3375 Motor Ave.
Los Angeles, CA 90034
310-989-4295
Website: www.echoartstudio.com
Offering classes, tools, supplies, clay, the Echo Clay-pron, and high-fire glazes in dry and wet form.

ELAN TRANSFERS

5610 Jefferson Boulevard, Frederick, MD 21703
Website: www.elantransfers.com
Elan Transfers provides fun, unique, and high-quality underglaze decals for contemporary ceramic artists to use on their own pottery. Offering over 400 different designs in a range of colors and styles.

ENDURING IMAGES

14818 W 6th Ave. #10-A
Golden, CO 80401
303-278-8868 Toll-Free: 800-905-3295
Website: www.ceramicprinting.com

EUCLID'S ELEMENTS/THE POTTERY SUPPLY HOUSE

1120 Speers Rd.
Oakville, ON L6L 2X4, Canada
905-849-5540 Toll-Free: 800-296-5456
Website: www.euclids.com
Offering pottery supplies, replacement elements and kiln parts, thin silicon-carbide kiln shelves, and Euclid's Choice products including stainless-steel texturing and detail tools.

EVANS CERAMIC SUPPLY

1518 S. Washington
Wichita, KS 67211-0654
316-262-2551
Website: evansceramics.com
Supplying schools, colleges, universities, and institutions, plus hobbyists and finished ware producers with products, service, and advice.

EVENHEAT KILN INC.

6949 Legion Rd.
Caseville, MI 48725-0399
989-856-2281
Website: www.evenheat-kiln.com
Manufacturing kilns. Available kiln accessories include RampMaster III and Set-Pro computer controls, TAP Controls, PC-based kiln software, mobile app software, pyrometers, Ventmaster, kiln shelves, and kiln posts.

FAT CAT POTTERY INC.

2500 Blue Clay Rd.
Wilmington, NC 28405
910-395-2529
Website: www.fatcatpottery.com
Offer classes and working studio space by the hour or month. Distributor for Skutt kilns, L&L Kilns, Laguna, Standard Ceramics clays, Mudtools, Spectrum glazes and underglazes, Amaco glazes and pottery wheels.

FLECKS AND SPECKS

Missoula, MT
Website: www.flecksandspecks.com
Offers bright colors of grog at all temperatures of ceramic firings to add color, texture, and durability to all types of clay. Flecks + Specks Grog is available in an ever-changing palette of colors and four sizes suitable for any method of working with clay.

FLORIDA CLAY ART CO.

1645 Hangar Rd.
Sanford, FL 32773
407-330-1116
Website: www.flclay.com
Distributor for Standard Clays, Amaco, Duncan, and Mayco glazes, and Kemper Tools. Also offer many types of pottery equipment including Cress Kilns, Skutt Kilns, Shimpo tools, Peter Pugger products.

FREE FREIGHT POTTERY SUPPLY LLC

5107 Edith Blvd. NE
Albuquerque, NM 87107
877-344-2933
Website: www.freefreightpotterysupply.com
Sells clay, glazes, kilns, wheels, tools, chemicals, stains. Free freight on everything all the time—even clay.

FREEFORM CLAY & SUPPLY

1912 Cleveland Ave.
National City, CA 91950
619-477-1004
Website: www.freeformclay.com
Supplier and distributor for Laguna Clay, Duncan Glazes, Kemper Tools, Skutt Kilns, Peter Pugger, North Star, Shimpo, L&L, Giffin Tec, and Cress Kilns.

GARE INC.

165 Rosemont St.
Haverhill, MA 01832
978-373-9131 Toll-Free: 888-289-4273
Website: store.gareceramics.com
Offering 700+ bisque designs and hundreds of glazes.

GEIL KILNS

7201 Clay Ave.
Huntington Beach, CA 92648
714-847-6135 Toll-Free: 800-887-4345
Website: www.kilns.com
Manufacture portable downdraft gas kilns, electric-fired kilns, gas burners and controls, and industrial furnaces.

GEORGIES CERAMIC & CLAY CO. INC.

756 NE Lombard
Portland, OR 97211
503-283-1353 Toll-Free: 800-999-2529
Website: www.georgies.com
Full range of equipment, supplies, and tools. Manufacturing clays and cone-6 oxidation glazes: PG600 series Gloss Glaze and GLW series Sculptural Textural Glaze, and our NEW cone 5-6 Tie Dye and Satin line of glazes. Tiles and Bisque: cone-6 green and bisque tile.

GIFFIN TEC INC.

4135 Sunny Hill Ln.
Lummi Island, WA 98262
360-758-7008
Website: www.giffingrip.com
Manufacturing the Giffin Grip and Lidmasters pottery tools.

GLASER CERAMICS

2325 Kimarra Pl.
Lincoln, NE 68521
402-464-6454 Toll-Free: 800-284-7299
Website: glaserceramics.com
Slip-casting equipment, pouring tables, slip-mixing equipment, and casting products.

GLAZE QUEEN

5240 Aero Dr. Ste. C,
Santa Rosa, CA 95403
707-260-2923
Website: www.glazequeen.com

GLOST GLAZES

Unit 5-104, Harrington Way, Warspite Rd., London
Website: www.glost-glaze.com
Offering ready-to-use sculptural and functional glazes.

GLYPTIC MODELING TOOLS

418 W. 8th St. SE Unit B5
Loveland, CO 80537
970-663-5190 Toll-Free: 800-260-4690
Website: www.glyptic.com
Offering tools in a variety of sizes and loop shapes for modeling and cutting/trimming.

GR POTTERY FORMS

2215 29th Street SE Ste. A4
Grand Rapids, MI 49508
616-551-3573
Website: www.grpotteryforms.com
GR Pottery Forms is leading the industry in wooden molds, which we call forms. Durable and economical. Ideal to make dinnerware and platters.

GREENBARN POTTERS SUPPLY LTD.

9548 192nd St.
Surrey, BC V4N 3R9, Canada

604-888-3411

Website: greenbarn.com
Supplying clay, materials, glazes, tools, equipment, and books.

HAMMILL & GILLESPIE INC.

869A State Route 12
Frenchtown, NJ 08825
973-822-8000 Toll-Free: 800-454-8846
Website: www.hamgil.com
Distribute ceramic raw materials including English china and ball clays, Cornish stone, Yorkshire whiting, and Spanish red-iron oxide. Manufacture Gillespie borate.

HIGHWATER CLAYS OF FLORIDA

3635 131st Ave. N.
Clearwater, FL 33762
727-553-9344
Website: highwaterclays.com
Offering over 30 clay bodies, glazes, tools, equipment, books, and more. Open Tuesday-Friday 10am-5pm, Saturday 10am-1pm.

HIGHWATER CLAYS, INC.

600 Riverside Dr., Asheville, NC 28801-2140
828-252-6033
Website: highwaterclays.com
Tools, kilns, glazes, equipment, raw materials, books, and prepared clay bodies.

HYPERGLAZE/RICHARD BURKETT

6354 Lorca Dr.
San Diego, CA 92115-5509
619-518-3019
Website: www.hyperglaze.com
HyperGlaze is an easy-to-use glaze database and calculator for ceramic artists. Runs on latest Macintosh and Windows computers. Store recipes, photos of glazes, recalculate batches and UMFs.

INDUSTRIAL MINERALS CO.

7268 Frasinetti Rd.
Sacramento, CA 95828
916-383-2811
Website: www.clayimco.com
Provide products and services for ceramic art markets. Manufacture a wide range of clays.

INNOVATIVE CERAMIC CORP.

432 Walnut St. Dept. 11
East Liverpool, OH 43920-3130
330-385-6515
Website: www.innovativeceramic.com
Supplying product identification and decoration solutions, decal squeegees, underglaze pencils, and china markers. Manufacture decals, rubber stamps, and DuraFire inks.

INSULATING FIREBRICK, INC.

899 Bedford St.
Claysburg, PA 16625
724-282-1012
Website: www.insulatingfirebrick.com
Supplying first quality ISO-certified insulating firebrick, 2300-3000°F (1260-1649°C), standard sizes and oversized bricks, straights and shapes

J.T. MCMASTER & SON

9300 E. Florida Ave #402
Denver, CO 80247
303-589-5776
Website: j-t-mcmaster.myshopify.com
Online store specializing in custom and open-source ceramic transfers.

JEN ALLEN CERAMICS

Morgantown, WV
Website: www.jenniferallenceramics.com
Designed for makers, teachers, and clay enthusiasts by a seasoned expert with 30 years of experience, these pottery patterns are meticulously crafted. Each template comes with step-by-step instructions, comprehensive materials and tools lists, and the option to purchase a video tutorial for a full instructional workshop.

JEN-KEN KILNS
3615 Ventura Dr. W.
Lakeland, FL 33811
800-329-5456
Website: jenkenkilns.com
Offering different types of kilns including glass-fusing kilns.

JIFFY MIXER CO. INC.
591 N. Smith Ave. Unit B
Corona, CA 92878
951-272-0838
Toll-Free: 800-560-2903
Website: www.jiffymixer.com
Offering a mixer with a three-bladed mixing head for combining dry or liquid ingredients. Available in a range of sizes; operated by ¼- to ¾-inch chucked power tools.

JOHNSON GAS APPLIANCE CO.
1155 Sherman Road
Hiawatha, IA 52233
319-365-5267 Toll-Free: 800-553-5422 x121
Website: www.johnsongas.com
Development and manufacture of gas-burning equipment including many types of furnaces, kilns, and burners.

JUSTIN'S MAKERY
P.O. Box 2323, Clovis, CA, 93613
Website: www.justinsmakery.com
Maker of custom texture tools, throwing tools, stamps, and kits.

LITTLE CHIP TOOLS
Website: www.littlechiptools.com
Offers 3D-printed tools to help you explore your creativity through pottery including extruder dies, stamps, and cutters.

KEMPER TOOLS
13595 12th St., Box 696
Chino, CA 91710
909-627-6191 Toll-Free: 800-388-5367
Website: kempertools.com
Over 500 tools for clay.

KENTUCKY MUDWORKS
800 Floyd Dr. Ste. 110
Lexington, KY 40505
859-389-9681
Website: kymudworks.com
Classes and weekday/weekend workshops, clay, tools, supplies. Manufacturing Dirty Girl Pottery Tools.

THE KILN DOCTOR INC.
501 E. Main St.
Front Royal, VA 22630
540-636-6016
Toll-Free: 877-KILNDOC
Website: www.thekilndoctor.com
Providing maintenance, service, and repair of ceramic equipment and electric kilns with delivery, assembly, and instruction. Servicing DC, Delaware, Maryland, Virginia, and West Virginia. Supply store with products and parts shipped nationwide. Workshops and kiln firings available.

KILN SHIELD
33 Frederick Ave.
Medford, MA 02155
617-926-1802
Website: www.kilnshield.com
KilnShield® is the only patented solution that protects the soft brick from being damaged, with heavy-gauge galvanized steel. Provides a soft silicone foam cushion for a pleasant loading experience. KilnShield® equally displaces your weight while loading, making the process easier and causing less strain on your back.

KRUEGER POTTERY SUPPLY
1449 Strassner Dr.
Brentwood, MO 63144
314-963-0180 Toll-Free: 800-358-0180
Website: www.kruegerpottery.com
Supplier of materials, new/used equipment, kiln repair, and maintenance. Offering classes and workshops.

KRUMOR INC.
7655 Hub Pkwy No. 206
Valley View, OH 44125
216-328-9802
Website: www.krumor.com
Manufacture temperature sensors: thermocouples and RTD's.



L&L KILN MFG. INC.
505 Sharptown Rd.
Swedesboro, NJ 08085
856-294-0077 Toll-Free: 800-750-8350
Website: hotkilns.com

Kilns from test kilns to 100-cubic-foot production kilns. 3-year limited warranty on Easy-Fire, eQuad-Pro, Jupiter, DaVinci, and Easy-Load and eFL front-loading kilns. All kilns have L&L's patented hard ceramic element holders and durable construction.

LA MERIDIANA INTERNATIONAL CERAMICS SCHOOL
Località Bagnano, 135
Certaldo, Florence 50052, Italy
39 3772709500
Website: lameridiana.fi.it
Artist in residence and workshops about all ceramic topics taught by renowned ceramic artists.



LAGUNA CLAY CO.
14400 Lomitas Ave.
City of Industry, CA 91746
800-452-4862
Website: www.lagunaclay.com
Offering moist clay; glazes; custom blends (we blend the customer's formula for them); Pacifica potters wheels; Lockerbie kick wheels; Thorley kiln furniture; Laguna spray booths, gas and raku kilns; and major-brand electric kilns.

LAGUNA CLAY CO.
490 Kane Court
Oviedo, FL 32765
407-365-2600 Toll-Free: 800-843-7057
Website: www.lagunaclay.com

LAGUNA CLAY CO.
61020 Leyshon Dr.
Byesville, OH 43723
740-439-4355 Toll-Free: 800-762-4354
Website: www.lagunaclay.com

LARKIN REFRACTORY SOLUTIONS
2331 Varkel Way
Lithonia, GA 30058
678-336-7090 Toll-Free: 800-898-4532
Website: www.larkinrefractory.com
Refractory supply and construction company.

MARJON CERAMICS INC.
3434 W. Earl Dr.
Phoenix, AZ 85017-5284
602-272-6585 Toll-Free: 800-903-CLAY
Website: www.marjonceramics.com
Two locations offering pottery supplies, service, and equipment.

MARJON CERAMICS INC.
426 W. Alturas
Tucson, AZ 85705
520-624-2872
Website: www.marjonceramics.com

MASON COLOR WORKS INC.
250 E. 2nd St.
East Liverpool, OH 43920-5076
330-385-4400

Website: www.masoncolor.com
Manufacturing ceramic pigments used as colorants for clay bodies, glazes, underglazes, and engobes.

MASTER KILN BUILDERS
27607 Grenada Ave.
Farmington, MN 55024
612-250-6208
Website: www.kilnbuilders.com
Building custom kilns for schools, individual artists, and institutions throughout the US.

MEDALTA IN THE HISTORIC CLAY DISTRICT
713 Medalta Ave. SE
Medicine Hat, Alberta T1A 3K9, Canada
403-529-1070
Website: www.medalta.org
Offering an art residency space, as well as exhibition and education programs.

MID-SOUTH CERAMIC SUPPLY CO.
1416 Lebanon Pike, Ste. C
Nashville, TN 37210
615-242-0300 Toll-Free: 866-203-5286
Website: www.midsouthceramics.com
Manufacture Opulence Glaze. Supplier with complete line of pottery equipment and supplies.

MIDWEST CERAMICS LLC.
217 E. South St.
Plano, IL 60545
630-273-2119
Website: www.midwestceramics.com
Since 1966, supplying all items for the ceramic artist. We manufacture USA Ceramic Bisque, in our Plano, Illinois, facility.

MIGHTY MUD
1528 Island Home
Knoxville, TN 37920
865-595-1900
Website: www.mightymud.com
Offering studio rentals, pottery and sculpture classes, gallery sales, private classes, Spectrum and Amaco glazes, bisque and glaze firing, artist residency, etc.

MIKE CERV POTS
Kansas City, MO
Website: mikecervpots.myshopify.com
Produces a variety of laser-cut templates out of durable tar paper. They can be used many times when handled with care. Each template comes with instructions on how to customize and use it.

MINNESOTA CLAY CO.
2960 Niagara Ln.
Plymouth, MN 55447
763-432-0875 Toll-Free: 800-252-9872
Website: www.mnclay.com
We are a manufacturer and distributor supplying clay, glaze, and ceramic products.

MISSISSIPPI SCHOOL OF FOLK ARTS
5 E Franklin St.
Natchez, MS 39121
601-493-4242
Website: www.msfolkart.org
Offering classes, memberships, and workshops.



MKM POTTERY TOOLS LLC
1131 E. Wisconsin Ave.
Appleton, WI 54911
920-903-8918
Website: www.mkmpotterytools.com;
www.etsy.com/shop/mkmpotterytools
MKM Pottery Tools offers various size Hand Rollers for texturing clay including BHR, HR, and TW. Many sizes of Stamps from Sxcl extra large to Smr mini stamps. There are 2 different size decorating disks for design work, and many sizes of wood ribs. Many more tools are available at www.mkmpotterytools.com.

MOREAN CENTER FOR CLAY
420 22nd St. S.
St. Petersburg, FL 33712
727-821-7162
Website: www.moreanartscenter.org
Offering studio rental, clay supplies, gallery sales, and education.

MUDSHARK STUDIOS
4715 NE 136th Ave.
Portland, OR 97230
971-271-7441
Website: mudsharkstudios.com
Provides model and mold making along with various ceramic production services.



MUDTOOLS
PO Box 111
Bat Cave, NC 28710
828-625-1852
Website: www.mudtools.com
Offering tools by Michael Sherrill.

NABERTHERM, INC.
54 Read's Way
New Castle, DE 19720
302-322-3665
Website: www.nabertherm.com
Offering German-made, high-firing top- and front-loading kilns and warranties.

NASCO ARTS & CRAFTS
901 Janesville Ave. PO Box 901
Fort Atkinson, WI 53538
1-800-558-9595 Toll-Free: 1-800-372-1236
Website: www.nascoeducation.com
Offering classroom and studio ceramic supplies.

NATIONAL ARTCRAFT CO.
300 Campus Dr.
Aurora, OH 44202
330-562-3500 Toll-Free: 888-937-2723
Website: www.nationalartcraft.com
Providing clock and musical movements, lamp-making parts, display hardware, and frames.

NATIONAL COUNCIL ON EDUCATION FOR THE CERAMIC ARTS (NCECA)
4845 Pearl East Circle, Ste. 101
Boulder, CO 80301
866-266-2322
Website: www.nceca.net
NCECA advances creation, teaching, and learning through clay in the contemporary world.

NEWBERRY ARTS CENTER
1200 Main St., Newberry, SC 29108
803-321-1022
Website: www.newberryartscenter.com
Includes programs for all ages.

NEW CENTURY CERAMIC ARTS INC.
Queen Anne Station PO Box 9060
Seattle, WA 98109
206-284-7805
Website: www.newcenturyartsinc.com
Offering P'Clay® and P'Slip® high-performance ceramic paperclay from Rosette Gault and licensed manufacturers, books, DVDs, and support.

STUDIOPRO (NEW ENGLAND HARDBOARD CO.)
726 Town Hill Rd.
Whitingham, VT 05361
802-368-2807
Website: www.studioprobats.com
Proudly offering throwing bats made from 4 quality materials, a selection of tools for wheel throwers and a new insert bat system that is fully cross compatible with the now unavailable Wonderbat™. Our bats are precision CNC manufactured and available in a full range of sizes.

NEW MEXICO CLAY, INC.
3300 Girard NE
Albuquerque, NM 87107
505-881-2350 Toll-Free: 800-781-2529
Website: www.nmclay.com
Distributor for Duncan & Mayco paints and glaze, cone 6 glazes from Coyote, Amaco, Laguna, Duncan, and Mayco. Skutt kilns, Shimpo and Brent wheels. We make clay for the Southwest, including Mica Red, Chocolate & Fiberclay (that never rots). Many tools and precious-metal silver clay.



NIDEC-SHIMPO CERAMICS
175 Wall St.
Glendale Heights, IL 60139
206-762-3239 Toll-Free: 800-237-7079
Website: www.shimpo ceramics.com

NORTH STAR EQUIPMENT INC.
1341 W. First St.
Cheney, WA 99004
509-235-9200 Toll-Free: 800-231-7896
Website: www.northstarequipment.com
USA-manufactured slab rollers and extruders with lifetime warranties, custom and stock extruder dies, ware carts, drying/damp cabinets, wedging tables, studio worktables, and throwing bats.

OLD FARMHOUSE POTTERY
232 County Road 1805
Rusk, TX 75785
903-795-3779
Website: www.farmpots.com
Publisher and seller of EXTRUDE IT! instructional DVD extruder videos.

OLD HICKORY CLAY CO.
962 State Route 1241
Mayfield, KY 42066
270-247-3042 Toll-Free: 800-242-6885
Website: www.oldsickoryclay.com
Produce ball clays for all types of ceramics, including slip casting, moist clay, modeling, and glaze formulations.

OLSEN KILN KITS
60520 Manzanita Rd.
Mountain Center, CA 92561
760-349-3291
Website: www.olsenkilns.com
Offering Olsen Gas Kiln Kits: 12, 16, 24, 36, 50, 72, and 100 cubic foot kilns. Offering Olsen Super E wood-fired kiln kits: 12, 16, 24, and 36 cubic-foot sizes.

OLYMPIA ENTERPRISES, INC.
715 McCartney Rd.
Youngstown, OH 44505
330-746-2726
Website: www.olympiadecals.com
Offer imported decals, chinaware, plates, and sponges along with brushes and tools made in the US.

OLYMPIC KILNS
4225 Thurmon Tanner Pkwy, PO Box 1347
Flowery Branch, GA 30542
770-967-4009 Toll-Free: 800-241-4400
Website: www.olympickilns.com
Manufacturer of electric and gas kilns for ceramics, pottery, glass, and heat-treating. Custom kilns quoted upon request.

ONEIDA AIR SYSTEMS, INC.
1001 W. Fayette St.
Syracuse, NY 13204
315-476-5151 Toll-Free: 800-732-4065
Website: www.oneida-air.com/ceramic
Oneida Air Systems makes the Dust Cobra, a cyclonic industrial HEPA vacuum that can safely clean up clay dust and glazes. Can be used mobile or stationary with up to 100 feet of hose. Replacement filters are affordable and easily obtained.

ORIGINAL HI ROLLER (POTTERY CAROLINA, LLC)
2161 Old Pamlico Beach Road
Belhaven, NC 28601
828-308-2585
Website: www.originalhiroller.com
Manufacturers of the Original Hi Roller—The Vertical Slab Roller.

ORTON CERAMIC FOUNDATION
PO Box 2760
Westerville, OH 43086-2760
614-895-2663
Website: www.ortonceramic.com
Manufacturing pyrometric cones, downdraft kiln venting systems, and electronic controllers for electric kilns.

PAASCHE AIRBRUSH CO.
9511 58th Pl., Kenosha, WI 53144
773-867-9191
Website: www.paascheairbrush.com
Offers airbrushes, industrial sprayers, support equipment.

PARAGON INDUSTRIES, L.P.
2011 S. Town East Blvd.
Mesquite, TX 75149-1122
972-288-7557
Toll-Free: 800-876-4328
Website: www.paragonweb.com
Manufacture cone-10 electric kilns, including top loaders, front loaders, and small glaze test models.

PCF STUDIOS
PO Box 722, Honeoye, NY 14471
585-229-2976
Website: philippefaraut.com
Offer instructional books and DVDs, as well as sculpting aids and workshops taught by artist Philippe Faraut.

PEBBLE PRESS, INC.
1610 Longshore Dr., Ann Arbor, MI 48105
734-327-0833
Website: www.piepenburgstudios.com
Offer books and DVDs.

PEEKSKILL CLAY STUDIOS, THE HAT FACTORY
1000 N. Division St. Suite #13A
Peekskill, NY 10566
914-739-2529
Website: www.peekskillclaystudios.com
Offers membership to experienced clay artists and classes and workshops for an expanding community of clay enthusiasts. Our gallery hosts several exhibitions each year and includes the work of members and invited artists.



PETER PUGGER MFG., INC.
3661 Christy Ln.
Ukiah, CA 95482
707-463-1333
Website: www.peterpuggger.com
Manufacturer of vacuum mixing pugmills, ball mills, kilns, studio presses, etc.



PETERS VALLEY SCHOOL OF CRAFT
19 Kuhn Road
Layton, NJ 07851
973-948-5200
Website: www.petersvalley.org
Offering immersive & virtual workshops in craft disciplines, fully equipped ceramic studio with atmospheric kilns, artist residencies, travel program & craft fair. The galleries feature 200+ American Craft Artists. Shop online www.petersvalleygallery.org.

PETRO MOLD COMPANY

12775 Donation Rd.
Waterford, PA 16441
814-796-6635
Website: www.petro molds.com
Offering both custom mold-making and mold-production services including original sculpting, master-mold design, production slip-casting, mold manufacturing, and stoneware bisque casting.

PHOENIX CERAMIC & FIRE SUPPLY

824 L St., Arcata, CA 95521
707-822-4556
Website: www.phoenixceramic.shop
Supplying clay, tools, glazes, equipment, materials, books, and magazines.

PINCH

179 Main St.
Northampton, MA 01060
413-586-4509
Website: www.pinchgoods.com

PLAINSMAN CLAY LTD.

671 Industrial Ave.
Medicine Hat, AB T1A 3L5, Canada
403-527-8535
Website: plainsmanclays.com
Manufacture blended pottery clays ranging from low to high temperatures, from our own clay deposits.

PLINTH GALLERY

3520 Brighton Blvd.
Denver, CO 80216
303-295-0717
Website: www.plinthgallery.com
Design and prototype/sample maker for ceramics and pottery; master mold and model maker for slip casting. Clay and glaze consulting service. L&L Kilns, Paragon, and Nabertherm Kilns distributor.

PORTLAND POTTERY STUDIOS AND GALLERY

118 Washington Ave.
Portland, ME 04101
Toll-Free: 800-539-4301
Website: www.portlandpottery.com
Offering wholesale/retail supplies including clays, raw materials, kilns, wheels, glazes, and tools.

PORTLAND POTTERY SUPPLY

220 Anderson St.
Portland, ME 04101
207-772-4334
Website: www.portlandpottery.com

PORTLAND POTTERY SUPPLY SOUTH

87 Messina Dr.
Braintree, MA 02184
781-848-2772 Toll-Free: 800-876-2776
Website: www.portlandpottery.com

THE POTTER'S CENTER

110 Ellen St.
Garden City, ID 83714-4605
208-378-1112 Toll-Free: 800-498-1126
Website: thepotterscenter.com
Shipping throughout the US. Offering clays, wheels, and a complete line of ceramic and pottery supplies.

THE POTTER'S SHOP

1314 S. West Ave.
Waukesha, WI 53186
262-547-1920
Website: www.pottersshop.com
Midwest supplier of clay, glaze, tools, pottery wheels, kilns, and other related products. We offer classes, workshops, studio membership, and repair services.

THE POTTERS SHOP AND SCHOOL

31 Thorpe Rd.
Needham, MA 02494
781-449-7687
Website: www.thepottersshopandschool.com
Offering over 800 books and videos. Providing studio membership, firing, and services for clay workers.

POTTERY TEXTURE QUEEN

Santa Rosa, CA
704-494-6265
Website: potterytexturequeen.com
Offering large texture stamps for potters that work well on slabs as well as thrown work. Over 20 available patterns. Also great for printing with underglazes/slips.

POTTERYVIDEOS.COM

1665 EL Verano
Gabriola, BC V0R 1X6, Canada
250-247-8109 Toll-Free: 800-668-8040
Website: www.potteryvideos.com
Produce and distribute educational videos on ceramic arts. 21 titles for potters of all levels. Hosted by artists Robin Hopper, Gordon Hutchens, and Graham Sheehan.

PURE & SIMPLE POTTERY PRODUCTS

2354 Baywood Way
Willits, CA 95490
707-354-4860
Website: pureandsimplepottery.com
Offering keyed plaster-bat molds, both domed and flat, in 11 shapes and sizes. Reversible SlumpHump molds in 16 shapes and sizes. Both flat and curved drape molds.

QUEEN CITY CLAY

2760 Highland Ave.
Norwood, OH 45212
513-871-2529 Toll-Free: 866-GET-CLAY
Website: www.queencityclay.com
Supply ceramic materials and equipment. Studio facilities/rental. Classes and workshops.

R.T. VANDERBILT CO. INC.

30 Winfield St.
Norwalk, CT 06855-5150
203-295-2141 Toll-Free: 800-243-6064
Website: www.rtvanderbilt.com
Supply raw materials for ceramics, including Peerless® Kaolin clay, Vansil® wollastonite and Pyrax pyrophyllite; also supply processing agents such as Darvan® dispersants, Veegum® suspension, and plasticizing clays.

RAM PRODUCTS INC.

1091 Stimml Rd.
Columbus, OH 43223
614-443-4634
Website: www.ramprocess.com
Manufacture forming, finishing, and glazing equipment and molds and models for studio and industrial potteries.

RESCO PRODUCTS INC.

3514 W. Wendover Ave.
Greensboro, NC 27407
336-299-1441 Toll-Free: 888-283-5547
Website: www.rescoproducts.com
Manufacture raw materials, refractory block for ceramic applications, and basic clay industry. Cedar Heights Clay produces Goldart, Redart, Roseville, Salt Lick, and assorted mesh sizes in Bond Clay and Fireclay.

RINGS & THINGS WHOLESAL

1011 E 2nd Ave. #6
Spokane, WA 99202
509-252-2900 Toll-Free: 800-366-2156
Website: www.rings-things.com
Retail and wholesale supplies—jewelry kilns, brushes, glass equipment and supplies, and more. Education and training. Daily shipping.

RITUAL GLAZE

2300 SE 7th Ave, Portland, OR 97214
Website: www.ritualglaze.com
Ritual Glaze is a 100% female-owned and operated startup providing special effects glazes.

ROCHESTER CERAMICS, INC.

102 Commercial St.
Webster, NY 14580
585-872-6190
Website: www.rochesterceramics.com
Offering Laguna glazes, raw materials, and Pacifica wheels. Dealer/distributor for Laguna clays and slip;

L&L Kilns; Paragon, Peter Puggger, and Lehman Studio equipment; Kemper tools; AMACO; and Duncan's complete line.

ROVIN CERAMICS

253 Dino Dr., Ste. A
Ann Arbor, MI 48103
734-424-3345
Website: www.rovinceramics.com
Supplies glaze, clay, tools, and large equipment. Manufactures 20 varieties of moist clay, and a line of low-fire glaze and underglazes all economical, and AP-certified non-toxic.

ROYAL & LANGNICKEL BRUSH MFG.

515 W. 45th St.
Munster, IN 46321
219-660-4170 Toll-Free: 800-247-2211
Website: art.royalbrush.com
Offers brushes with natural and synthetic hair, tools for a variety of clay and pottery applications, along with natural and synthetic sponges.

RUNYAN POTTERY SUPPLY INC.

Clio Industrial Park—820 Tacoma Ct.
Clio, MI 48420
810-687-4500
Website: www.runyanpotterysupply.com
Manufacture moist pottery clay and distribute complete line of ceramic equipment and supplies. Repair help, parts, and quick shipment of your order. Call for a free catalog.

RUSTY KILN CERAMIC STUDIO

136 Boulevard Rd.
North Windham, CT 06256
860-423-1550
Website: www.rustykiln.com
Offering clay, glazes, tools, brushes, kilns, wheels, pug mills, venting systems, slab rollers, extruders, as well as kiln and wheel servicing.

SAINT-GOBAIN CERAMIC MATERIALS

1 New Bond St., MS 301-432
Worcester, MA 01606
508-795-5264
Website: www.ceramicsrefractories.saint-gobain.com
Produces Advancer silicon nitride-bonded silicon-carbide kiln shelves. Also produces Crystolon oxide-bonded silicon-carbide kiln shelves. Our marketing partner is Smith-Sharpe Fire Brick Supply.

SAN ANGELO MUSEUM OF FINE ARTS

1 Love Street
San Angelo, TX 76903
325-653-3333
Website: www.samfa.org
Art museum with ceramics focus in its collections and programming. Major ceramics events and exhibition every April. Biennial juried competition, adult ceramics classes.

SAPIR STUDIOS

PO Box 6950, Chicago, IL 60680
773-794-0066 Toll-Free: 800-788-2588
Create clear acrylic, single-piece construction risers, original design plate stands, and bowl holders for upright and wall-mounted display. Custom fabrication available.

SCHOOL SPECIALTY/ SAX ARTS & CRAFTS

W6316 Design Dr.
Greenville, WI 54942
920-734-5712 Toll-Free: 800-558-6696
Website: select.schoolspecialty.com
Supplies, materials, and equipment including kilns, potter's wheels, clay, glazes, tools, etc., and resource materials.

SEATTLE POTTERY SUPPLY

35 S. Hanford St.
Seattle, WA 98134-1807
206-587-0570 Toll-Free: 888-915-1196
Website: www.seattlepotterysupply.com
Supplying kilns, clay, chemicals, books, and sundries.

SEQUOIA POTTERY (SLICKFOOT)

1681 Coy Flat Dr.
Springville, CA 93265
559-542-2203

Website: www.sequoiapottery.com

Diamond grinding discs and polishing pads for the potter's wheel. Double-sided diamond grinding disc with a coarse and fine side, ready to use, flip over to change grits. Diamond hand pads, water drip kit, and more.

SHALYA MARSH STUDIOS

Morgantown, WV
Website: www.shalyamarshstudios.com

Providing pre-cut tar paper stencils that will save you time, help you create repeatable patterns, and are designed by an artist for artists. Perfect for both newbies and seasoned makers!

SHEFFIELD POTTERY INC.

995 N. Main St.
Sheffield, MA 01257-0399
413-229-7700 Toll-Free: 888-774-2529
Website: www.sheffield-pottery.com

Supplying clay bodies, custom clay, kilns, wheels, tools, glazes, raw materials, bricks, refractories, books, DVDs, and more. Offering repair of kilns and wheels.

SIAL

2860 Blvd. Le Corbusier
Laval, QC H7L 3S1, Canada
450-687-4046

Website: www.sial-canada.com

Manufacture, distribute clay, glazes, kilns, wheels, equipment, tools, repair service.

SINISTRA STUDIO LLC

3333 Kingman St., Ste. 100
Metairie, LA 70006
504-812-3197

Website: www.sinistrastudio.com

Offering Alligator Clay, Amaco and Spectrum Glazes, Kemper, and Mudtools.

SILKPAINT

P.O. Box 18, Waldron, MO 64092
Website: www.silkpaint.com

Maker of The AirPen® Color Dispenser, a handheld, air-powered tool for drawing very fine decorative details or for filling intricate areas. Paints, glues, ceramic glazes, and other viscous mediums are effortlessly dispensed by placing a finger over the flow control hole. Anti-gravity piston "followers" allow you to work on a vertical surface. The patented product is drip-free and supplied with a 110V air pump.



SKUTT

SKUTT CERAMIC PRODUCTS

6441 SE Johnson Creek Blvd.
Portland, OR 97206-9552
503-774-6000
Website: www.skutt.com

Manufacture KilnMaster and Kiln Sitter electric kilns, Skutt/Thomas Stuart potter's wheels, EnviroVent 2 downdraft venting, EnviroLink, KilnSitter parts, and KilnLink monitoring system.

Smith-Sharpe Fire Brick Supply

SMITH-SHARPE FIRE BRICK SUPPLY

2129 Broadway St. NE
Minneapolis, MN 55413
612-331-1345 Toll-Free: 866-545-6743
Website: www.kilnshelf.com

Offering silicon-carbide kiln shelves (specializing in Advancer® brand), low-mass shelves for gas, and top-loading, multi-sided kilns. Offering refractory materials including firebrick, mortar, castable refractory, and ceramic fiber insulation. Technical assistance available.

SOCWELL LLC.

PO Box 719
Whitewater, WI 53190
920-728-0768
Website: www.4clay.com

Custom stamps and rollers made from your artwork or instructions for a physical mark in soft clay. Mug Logos stamps, free setups and proof layouts. Stock designs and signature stamps for ceramic artists and professional potters.

SOLDNER CLAY MIXERS BY MAMMOTH CLAY COMPANY

4221 N. Walnut Ave.
Oklahoma City, OK 73105
316-281-9132

Website: www.soldnerequipment.com

Offering Soldner clay mixers by Muddy Elbow Mfg.

SPECTRUM®

SPECTRUM GLAZES

273 Bowes Rd., Unit 1A
Concord, ON L4K 1H8, Canada
905-695-8355 Toll-Free: 800-970-1970
Website: www.spectrumglazes.com

Worldwide supplier of ceramic glazes focused on producing the highest quality, most diverse selection of fired finishes. We are also a distributor of various raw materials, such as frits and stains; pottery tools, such as stamps rollers and brushes; and kiln furniture, including shelves and posts.

SPEEDBALL ART PRODUCTS CO.

2301 Speedball Rd.
Statesville, NC 28677
704-838-1475

Toll-Free: 800-898-7224

Website: www.speedballart.com

Offering glazes and underglazes.

**ARE YOU A DISRUPTOR?
DO YOU TAKE EARTH AND
MAKE IT INTO HEAVEN?
ARE YOUR HANDS DIRTY
AND UNAPOLOGETIC?
CONTINENTAL CLAY
WELCOMES YOU, SUPPLYING
DISRUPTORS SINCE 1990**



Denver:

5303 East 47th Avenue • Denver, CO 80216

Minneapolis:

1101 Stinson Blvd NE • Minneapolis, MN 55413

800.432.2529 www.continentalclay.com

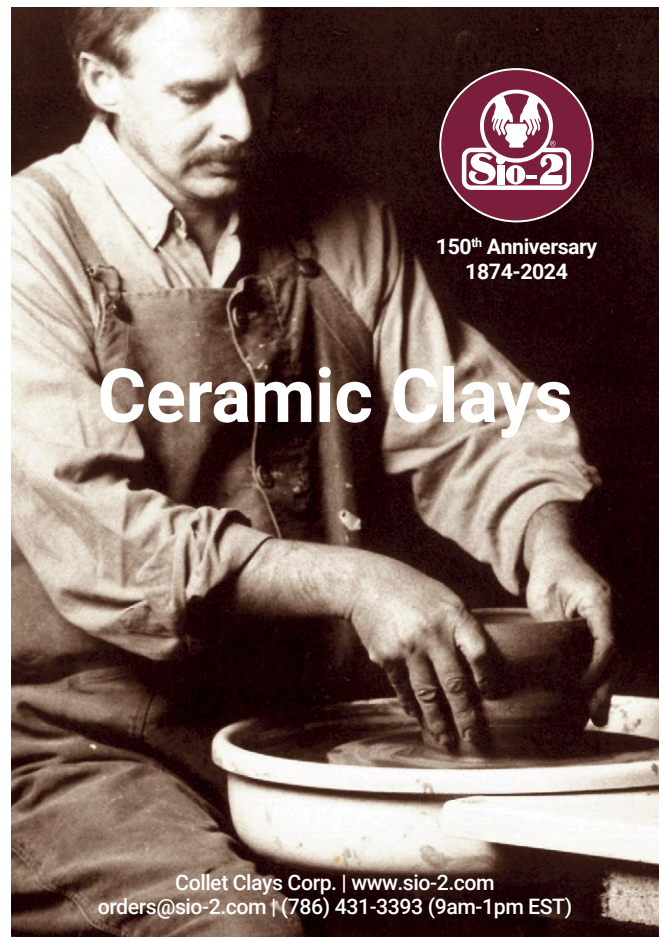



STANDARD CERAMIC SUPPLY CO.

PO Box 16240
Pittsburgh, PA 15242
412-276-6333
Website: www.standardceramic.com

Standard wet clays; raw clay and glaze materials; plasters; equipment and tools.

STARWORKS CERAMICS MATERIALS & RESEARCH

100 Russell Drive
Star, NC 27356
910-428-9007
Website: www.starworksn.org

Producing North Carolina Wild Clay bodies since 2009. Artist-in-Residency program, workshops, lectures, conferences, exhibitions. Tools, equipment, and supplies from Nidec-Shimpo, Standard Ceramics, High-water Clays, Mudtools, Kemper Tools, Speedball, Orton Cones, and others.

STARLITE MOLD COMPANY

1518 S. Washington
Wichita, KS 67211
316-262-2551
Website: www.starlitemolds.com;
www.dochoolidaymolds.net; www.evansceramics.com
Producing 12,000 mold designs.

STONE LEAF POTTERY

6611 West 58th Place
Arvada, CO 80003
303-463-8081
Website: stoneleafpottery.com
Offers a wide array of supplies for the ceramic aficionado including glaze, clay, raw materials, equipment, tools, and more.

STUDIOPRO

726 Town Hill Rd.
Whitingham, VT 05361
802-451-9182
Website: www.studioprobats.com
Proudly offering throwing bats made from 4 quality materials, a selection of tools for wheel-throwers and a new insert bat system that is fully cross compatible with the now unavailable Wonderbat™. Our bats are precision CNC manufactured and available in a full range of sizes.

STUDIO SALES AND SCHOOLHOUSE #3 POTTERY

5557 E. Avon Rd.
Avon, NY 14414
585-226-3030
Website: www.studiosalespottery.com

SUNSHINE COBB

Helena, Montana
Website: www.sunshinecobb.com
Supplies books highlighting handbuilding techniques written by ceramic artist Sunshine Cobb, as well as her Sunshine Stick measuring/cutting tool, and other helpful tools for handbuilding.

SUMMIT KILNS

PO Box 573
Land O Lakes, FL 34639
813-996-2575
Offering electric to gas conversions to convert your electric kiln to a gas kiln. Offer raku burners, Fiber-Frax, hi-temp wire, and controllers. New and used electric kilns and wheels. Kiln and potters wheel repair in central Florida. Dealer for Paragon, Skutt, and Olympic kilns.

TEXAS POTTERY SUPPLY & CLAY CO.

4401 Garland Dr.
Halton City, TX 76117
817-503-2022
Website: www.texaspottery.com
Full-service ceramic supply warehouse. Complete line of clay, equipment, tools, and supplies.

TIN BARN POTTERY SUPPLIES AT

MANASSAS CLAY
9122 Center St.
Manassas, VA 20110
703-330-1040
Website: www.manassasclay.com
Offering ceramics and pottery supplies.

TRINITY CERAMIC SUPPLY INC.

9016 Diplomacy Row
Dallas, TX 75247-5304
214-631-0540
Website: www.trinityceramic.com
Ceramics material supplier. Distribute Amaco/Brent, Creative Industries, Shimpo, Thomas Stuart, North Star Equipment, Spectrum glazes, Kemper Tools, Laguna Clays, Armadillo Clays, Pemco frits, and Cerdec ceramic stains. Manufacture Trinity brand moist clays.

TRINITY ENDEAVORS INTERNATIONAL

208 N. Main Ave.
Lake Placid, FL 33852
863-699-4082
Website: www.trinitydecals.com; www.tilesbyfran.com
Offering open-stock and custom silk screen and digital ceramic/porcelain and glass decals. Custom decorative ceramic and porcelain tile. Gift items as well as firing services for projects.



**TUCKER'S
Pottery Supplies Inc.**

TUCKER'S POTTERY SUPPLIES INC.

15 W. Pearce St. Unit #7
Richmond Hill, ON L4B 1H6 Canada
905-889-7705 Toll-Free: 800-304-6185
Website: tuckerspottteryeshop.com
Retail/wholesale, manufacture, distribute clay, glazes, tools, kilns, pottery wheels, slab rollers, extruders, and kiln elements. Repair service. Manufacturer of Cone Art Kilns.

U.S. PIGMENT CORP.

815 Schneider Dr.
S. Elgin, IL 60177
630-893-9217
Website: www.uspigment.com
Supply raw materials, stains, glazes, chemicals, rare-earth elements, specializing in cobalt, tin, nickel, chrome, and copper.

UNITED ART & EDUCATION

PO Box 9219
Ft. Wayne, IN 46899 Toll-Free: 800-322-3247
Website: www.unitednow.com
Serving schools, organizations, and individuals with quality products, since 1960. Low prices, volume discounts, and free shipping policy.

VENT-A-KILN CORP.

51 Botsford Pl.
Buffalo, NY 14216
716-876-2023 Toll-Free: 877-876-8368
Website: www.ventafume.com
Wide variety of kiln and fume vent-exhaust systems. Manufactures overhead kiln ventilation systems.

VULCAN KILNS

7623 Cloy Rd.
Centerville, OH 45459
937-433-1833
Website: www.vulcankilns.com
Manufacture electric hobby kilns. Sell kilns and kiln accessories, including kiln vents and controllers. Kiln repair, all brands. Wholesale bisque tile.

WARD BURNER SYSTEMS

PO Box 1086
Dandridge, TN 37725
865-397-2914
Website: www.wardburner.com
Provide equipment for kilns and furnaces, including venturi burners, power burners, and a line of raku burners.

WENDT POTTERY

2729 Clearwater Ave., Lewiston, ID 83501
208-746-3724
Website: www.wendtpottery.com
Produce Helmer kaolin, a replacement for Avery kaolin in wood-fire bodies. Mixed cone-10 Helmer body now available.

WEST MICHIGAN CLAY

3765 Lincoln Road, Hamilton, MI 49419
269-751-5839
Website: www.westmichiganclay.com
Serving the needs of potters, schools, and hobbyists; consulting services; equipment repair and products from Standard, Laguna, L&L, Evenheat, Kemper, Dolan, Shimpo, Skutt Wheels, and Sterling Books.

WIZARD GLAZE

Portland, Oregon
Website: wizardglaze.com
Producer of special effect ceramics glazes with easy-to-master and consistent formulas.

WIZIWIG TOOLS

4101 Myers Ave.
Crestwood, KY 40014
Website: www.wiziwigttools.com
WiziWig Tools manufactures Profile Ribs that help create consistent shapes. Creates TouchUp Sponges for smoothing tight spaces, ClayShield for containing clay trimmings, and Cavity Sticks for handbuilding.

XIEM TOOLS USA

1563 N. Lake Ave.
Pasadena, CA 91104
626-794-5833
Website: www.xiemclaycenter.com
Offering classes, studio memberships, gallery, retail store with pottery tools, clays, glazes, and books. Manufacture Xiem Studio Tools including art rollers, art bags, precision applicators, and flexible rulers.

All your clay needs is...

Cornell Studio Supply
8290 N Dixie Dr
Dayton, Ohio 45414

CornellStudioSupply.com

ceramicRECIPES
Get excited. Get involved. Get results.

EASILY ACCESS HUNDREDS OF CERAMIC RECIPES

Iron Oxide Slip Water Blue Poppyfield Glaze

**Start building your recipe collection—
SUBSCRIBE TODAY!**

ceramicrecipes.org
CERAMIC ARTS NETWORK



LISTEN TO ceramics

M O N T H L Y

Imagine it:
You are working
in your studio as
Ceramics Monthly
is READ to you!

Now you can LISTEN to the featured articles in each issue online, from the January 2023 issue onward!

To access Audio Articles, simply log in to your account on our site if you have one of the following subscriptions or memberships:

- A *Ceramics Monthly* All-Access subscription
- A *Ceramics Monthly* Web-Only Subscription (includes former Tablet subscribers!)
- An ICAN Gold or Silver membership

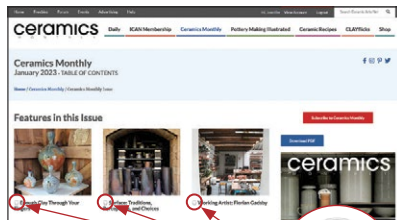

LOOK FOR THE HEADPHONES ICON TO FIND AUDIO ARTICLES!



SCAN TO SUBSCRIBE TODAY!

SUBSCRIBE AND LISTEN TODAY! mycan.ceramicartsnetwork.org/s/subscriptions

*Please note: Audio Articles are not available for *Ceramics Monthly* print-only subscribers or ICAN Standard members. Interested in upgrading your subscription? Email us at customerservice@ceramicartsnetwork.org for more details.

We've Got It All! Pottery Equipment & Supplies

- TOOLS
- CLAY
- WHEELS
- KILNS
- CARTS
- SHELVES
- GLAZE
- BOOKS

and Service
with a Smile!



Toll Free 1-888-503-2299

INDEX to ADVERTISERS

Aardvark Clay	40	ICAN.	72
Alligator Clay Company.	71	Laguna Clay Company.	19
Amaco and Brent	14	LL Kiln Mfg.	Cover 2
Arrowmont.	41	MKM	47
Blick	1	Mudtools	41
Carolina Clay Connection	71	Nidec-Shimpo	3
Ceramic Arts Network Shop.	70, 71	Peter Puggger Mfg	31
Chinese Clay Art	40	Peter's Valley	47
Clay Art Ctr/Scott Creek	40	Skutt.	Cover 4
CM/PMI Subscriptions.	55, 56, 71	Smith-Sharpe	30
Collet Clays Corp.	69	Spectrum Glazes.	Cover 3
Continental Clay	69	Standard Clay Company	47
Cornell Studio Supply	70	Tucker's Pottery.	2
Cress Mfg	41		



Carolina Clay Connection

Charlotte's best-stocked pottery supply and equipment resource since 1995



Clays

Glazes

Underglazes

Kilns & Accessories

Slab Rollers

Extruders

Raw Materials

Classes

Workshops

Carolina Clay Connection
 Phone 704.376.7221
 E-mail carolinaclay@aol.com
www.carolinaclay.com

Become a Member JOIN ICAN

Get Everything You Need to be a Better Ceramic Artist

Included With Your Membership, You Get:

- ✓ **CLAYflicks**
Watch and Learn
- ✓ **Subscriptions to**
Ceramics Monthly and
Pottery Making Illustrated
- ✓ **Archives: Access to**
Every Article We've
Ever Published
- ✓ **20% Shop Discount**
- ✓ **UPS Shipping Discounts**
- ✓ **Ceramic Recipes**
Database
- ✓ **Artist Portfolios**
- ✓ **Workshops and**
Cultural Tours
- ✓ **Members-Only**
Exhibitions



Magazine
Subscriptions

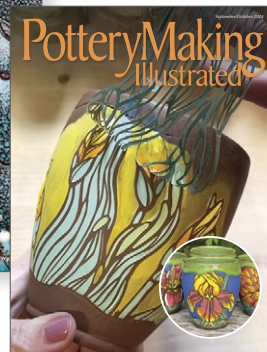

How-to Books,
Videos, and
Much More

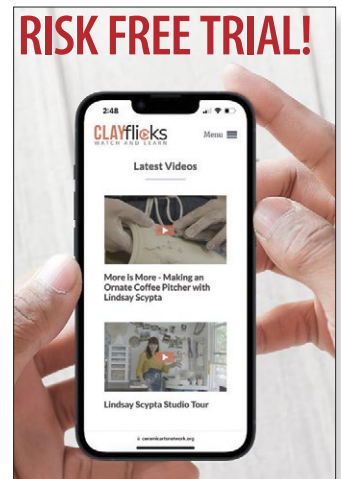

CLAYflicks



Artist Portfolios

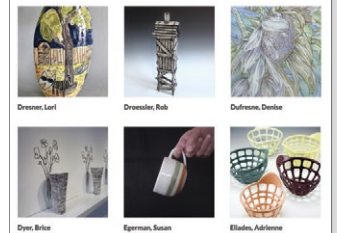

Ceramic Recipes Database

ICAN International
CERAMIC
ARTISTS
NETWORK



SCAN TO JOIN TODAY!

Learn more at ceramicartsnetwork.org/ican

spectrum® GLAZES

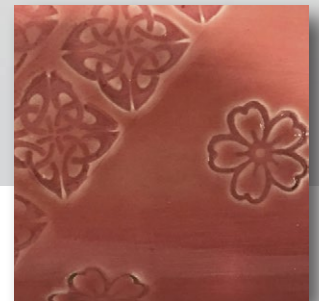
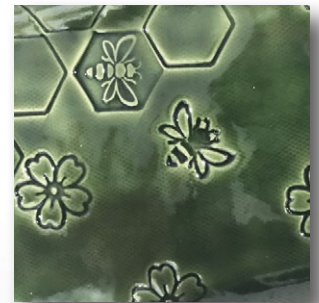
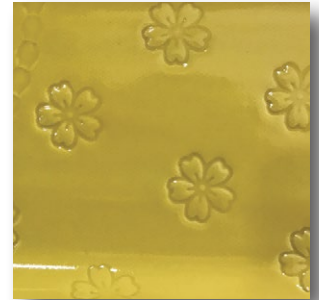

New Spectrum Stamps and Rollers

Relief stamps are made with 3D printers and leave a clearer and cleaner impression because they are made with a graduated angle to smoothly cut into clay. The angle allows you to make your impressions as deep as you like without leaving behind borders or messy lines. All stamps and rollers are made with biodegradable bioplastic material. Ask for these stamps at your local clay and glaze supplier.



All samples were glazed with Spectrum's Cone 5 Semi-Transparent glazes.

www.spectrumglazes.com • (800) 970-1970

For a free catalogue, please email: sales@spectrumglazes.com



SKUTT®



THE NEW OVAL



KMT1427-3

IT'S THE PERFECT STUDIO-SIZED KILN

We help you make great things!